

## B744V, B744VL, SS544V, B66V, B66VL

50 kHz, 120 kHz, 120 kHz Dual Beam,  
150 kHz, 170 kHz, 200 kHz, 235 kHz,  
50/200 kHz Dual Frequency,  
50 kHz & 200 kHz Dual Frequency

U.S. Patent No. 4,898,029  
U.S. Patent No. 5,186,050  
Canadian Patent No. 1,313,775  
Australian Patent No. 605,281  
Japanese Patent No. 1851014

Airmar TRIDUCER® multisensors incorporate a revolutionary self-closing valve to minimize water flow into the boat when the paddlewheel insert is removed. "Gushers" are eliminated with this simple to maintain valve.

Fins provide on either side of the paddlewheel for more accurate speed measurement in cross-flow conditions.

Combined with our fairing, installation is made simple. Made of urethane, the fairing will never swell or rot, and the unique cutting guide allows safer, more accurate cutting with a band saw. High speed fairings are provided with a corrosion resistant bolt to secure the fairing and prevent rotation.



## The Latest Evolution in TRIDUCER™ Multisensor Technology

Self-closing valve...checks water flow when paddlewheel insert is removed  
New B744V and long stem B744VL offer flush mounting in streamlined fairings and accommodate ceramics up to 44 mm (1.75") in diameter including the popular 50/200 kHz model

SS544 includes a streamlined fairing and is designed specifically for isolated mounting to steel and aluminum hulls. It accommodates ceramics up to 44 mm (1.75") in diameter

New streamlined fairings for B744V, B744VL, and SS544V provide much improved echosounding at speeds above 20 knots and greatly reduce drag

Versatile B66V and long stem B66VL mounts frequencies varying from 50 kHz to 200 kHz including dual beam 120 kHz and dual element 50 kHz & 200 kHz

Optional **paddlewheel-less** speed/temperature sensor uses echo correlation technology

### Specifications

- Hall-effect device senses paddlewheel rotation
- Unitary paddlewheel bearing assures exact alignment and minimal rotational friction
- Corrosion-proof shaft for long life in saltwater
- Alignment key for easy speed/temperature assembly removal and insertion in difficult access locations
- Replaceable valve assembly
- Polished paddlewheel shaft for quick start up
- Surge and reverse polarity protection
- Shielded cable to minimize noise pick-up and emission
- Designed to meet CE requirements
- Dual O-rings for superior sealing
- Retaining pin and safety chain secures paddlewheel and plug inserts
- Installation requires a 51mm (2") diameter hole
- Fairing is supplied standard with SS544V
- Blanking plug included
- Standard cable length: 10 m (33')
- Weight:
 

B744V	2.5 kg (5.5 lb.)
B744VL	2.6 kg (6.4 lb.)
SS544V	3.1 kg (6.8 lb.)
B66V	2.7 kg (6.0 lb.)
B66VL	3.1 kg (6.8 lb.)

### Options

- Two wire speed sensor circuit
- Thermistor or semiconductor temperature sensor
- Urethane fairing
  - B744V, B744VL: High speed #33-353-01
  - B66V, B66VL: Standard #33-029
- Pulse division circuitry or other pulse rates
- CS4500 correlation speed/temperature insert

## Applications

- Fiberglass or wood hulls only

## Notes

- Replaces B44, B50, B55, and B56 models
- For Parts and Accessories see pages p2 through p4

## Single Connector/ Dual Connector Systems

The piezoceramic element, speed, and temperature circuitry are all within the bronze housing. The removable paddlewheel insert contains no circuitry. The magnetic field sensor to measure speed is mounted in the housing in close proximity to the rotating paddlewheel. A single connector system is generally used when depth, speed, and temperature will be processed in a single instrument or when two instruments are within 1 m (40") of each other. When depth and speed/temperature functions will be processed in separate instruments, our cable can be split and two connectors can be applied.

All signals are transmitted via a multi-conductor cable with a high quality thermoplastic rubber jacket for improved resistance to cutting, pinching, and degradation from petroleum distillates. C144 cable is used in single element TRIDUCER® multisensors. Dual element multisensors use C145 cable.

Hull Thickness Limits		
Model	Minimum	Maximum
<b>B744V</b> with fairing	—	26 mm (1")
without fairing	6 mm (1/4")	72 mm (2 7/8")
<b>B744VL</b> with fairing	6 mm (1/4")	87 mm (3 3/4")
without fairing	35 mm (1 3/8")	133 mm (5 1/4")
<b>SS544V</b> with fairing	—	14 mm (1/2")
<b>B66V</b> with fairing	—	25 mm (1")
without fairing	6 mm (1/4")	70 mm (2 3/4")
<b>B66VL</b> with fairing	30 mm (1 1/8")	87 mm (3 3/4")
without fairing	70 mm (2 3/4")	133 mm (5 1/4")

## Speed

The TRIDUCER® multisensor provides accurate speed measurement over the widest boat speed range of any thru-hull paddlewheel transducer.

The combination of a hydrodynamic paddlewheel and paddlewheel cavity, housing and fairing projection through the boundary layer and fins on either side of the paddlewheel gives an unmatched linearity.

## Temperature

Various temperature sensing devices can be incorporated in the housing including thermistor and semiconductor types. See the "Temperature" section for more detailed information including thermal time constants.

## Shielding

Inside the TRIDUCER® multisensor housing, shielding is used to eliminate interference between the speed and depth sensors. A shielded cable and separately shielded speed and temperature conductors are used to prevent mutual interference. The bronze housing also functions as a shield. Refer to wiring diagram beginning on p 35 for shielding details.

Specifications <sup>1</sup>	
Speed range <sup>2</sup>	1–44 knots (1–50 MPH)
Linearity	Refer to <i>Airmar Technical Data Catalog</i>
Pulse rate (B744V,B744VL,SS544V)	19,000 ppm <sup>3</sup> (5.7 Hz/knot) with high speed fairing 21,500 ppm <sup>3</sup> (6.0 Hz/knot) without fairing
Pulse rate (B66V, B66VL)	21,500 ppm <sup>3</sup> (6.0 Hz/knot) with standard fairing 21,500 ppm <sup>3</sup> (6.0 Hz/knot) without fairing
Supply voltage	5–25 VDC
Supply current: "OFF" "ON"	2.3 mA 8 mA at 5 VDC
Circuitry: standard optional	3 wire format 2 wire format
Unicurve® type thermistor	10,000 ohms

1. Refer to "Sensor Design Fundamentals" for more detailed information.
2. Requires correction for non-linearity below 3 knots (3MPH).
3. ppm = pulses per nautical mile.

New • THRU-HULL • Depth • Speed • Temperature

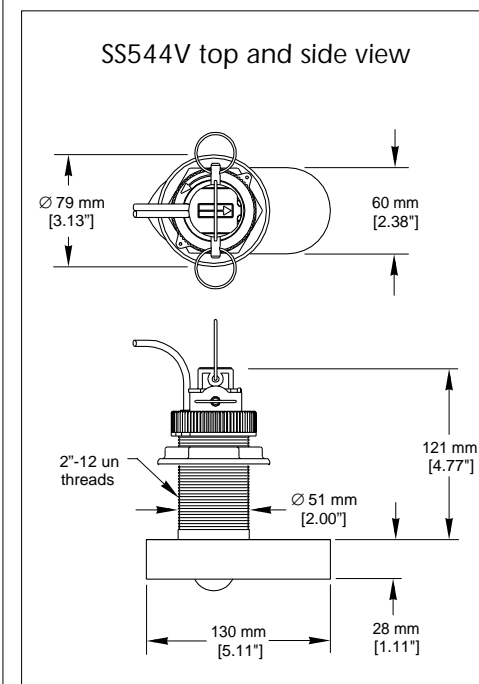
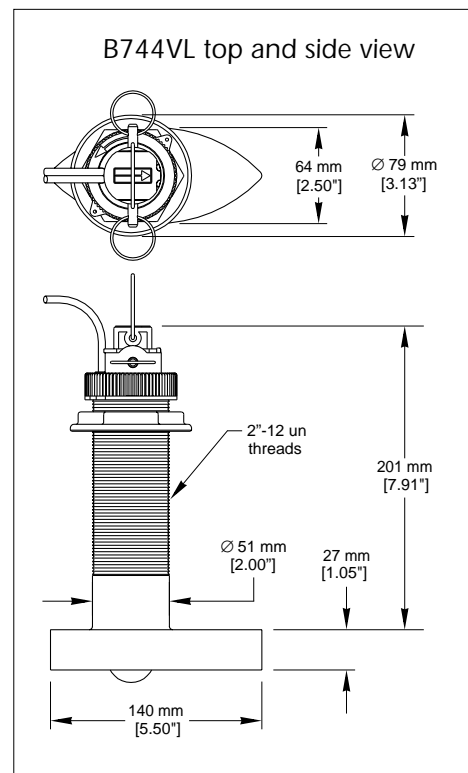
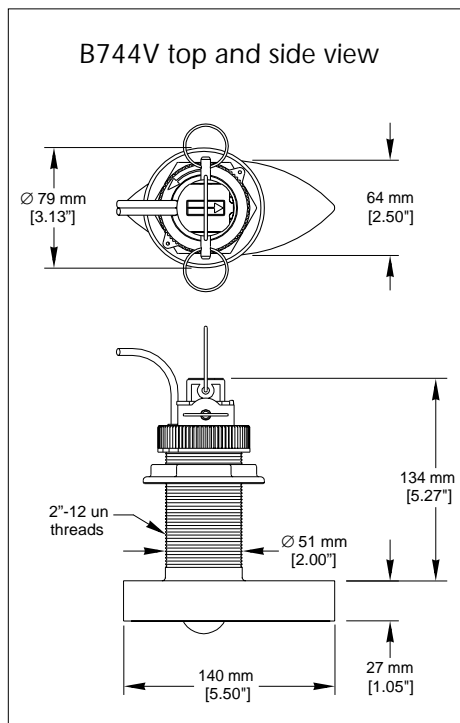

New • THRU-HULL MOUNT • Depth • Speed • Temperature

B66V, B66VL



Paddlewheel insert and blanking plug

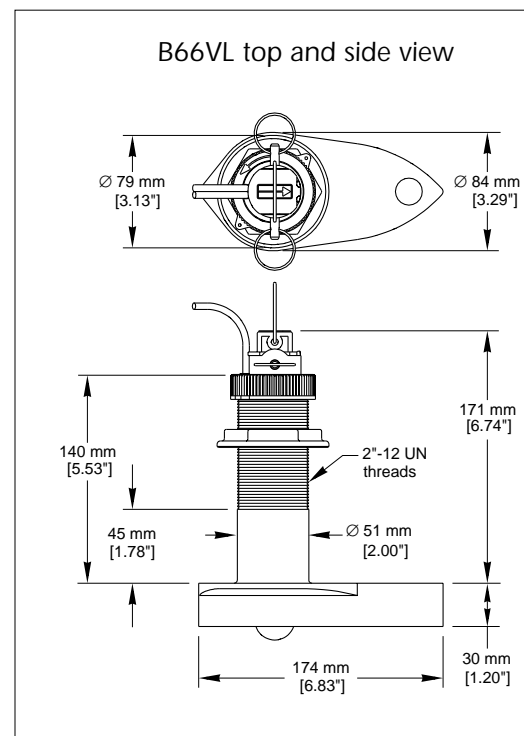
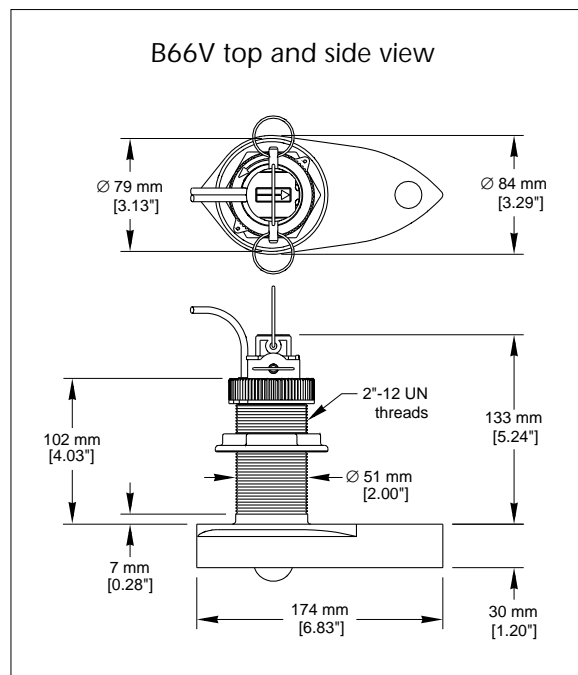
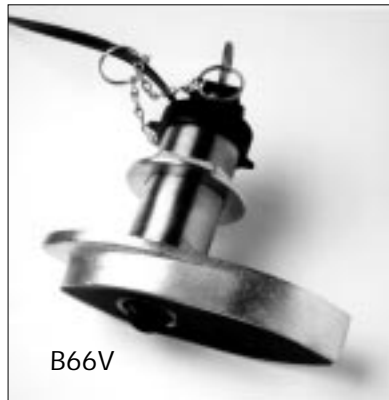

## TRIDUCER® Multisensor

- Self-closing valve assembly
- Improved speed measurement accuracy
- Same stem diameter and thread pitch as earlier housing
- Optional urethane fairing—impact resistant, keyed to housings, with unique cutting guide

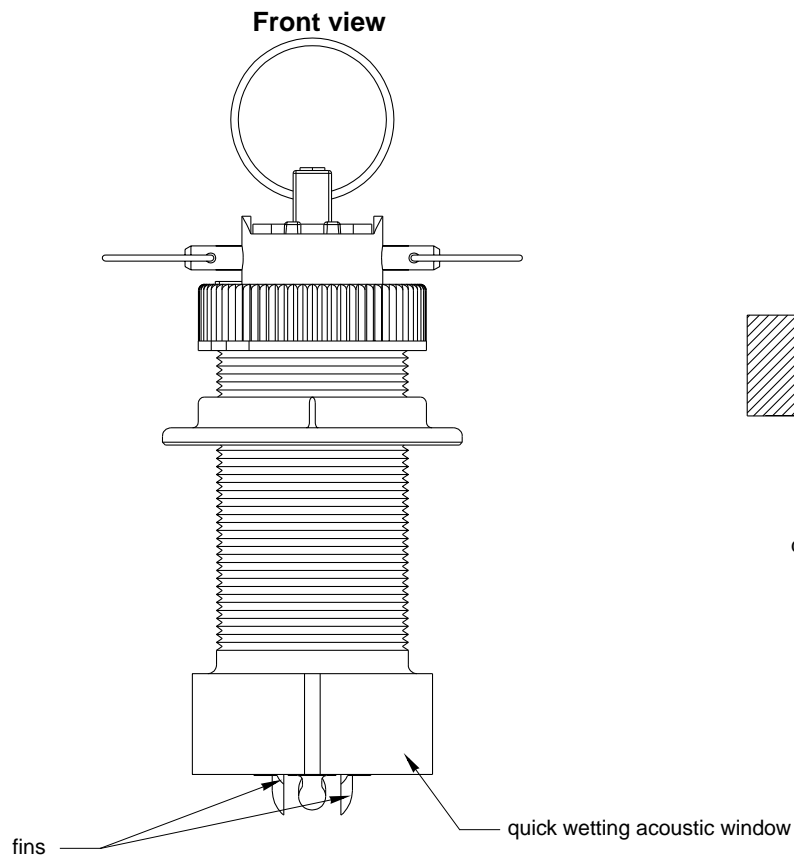

**Improved speed accuracy**  
Fins straighten water flow onto the paddlewheel improving accuracy at low speeds and in cross-flow conditions

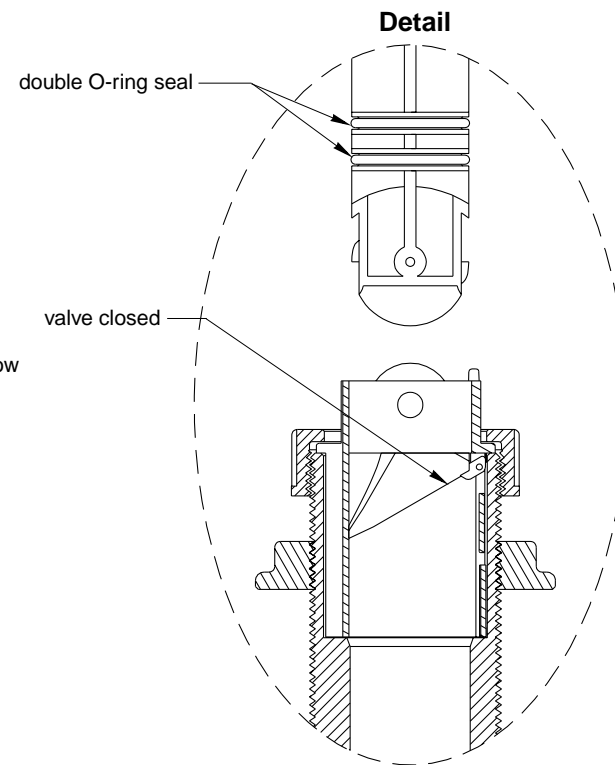
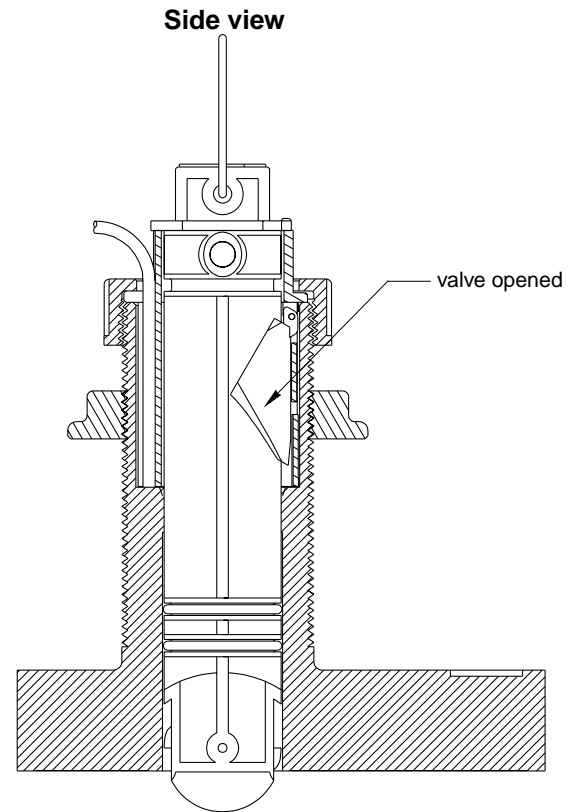

B744V  
Exploded View

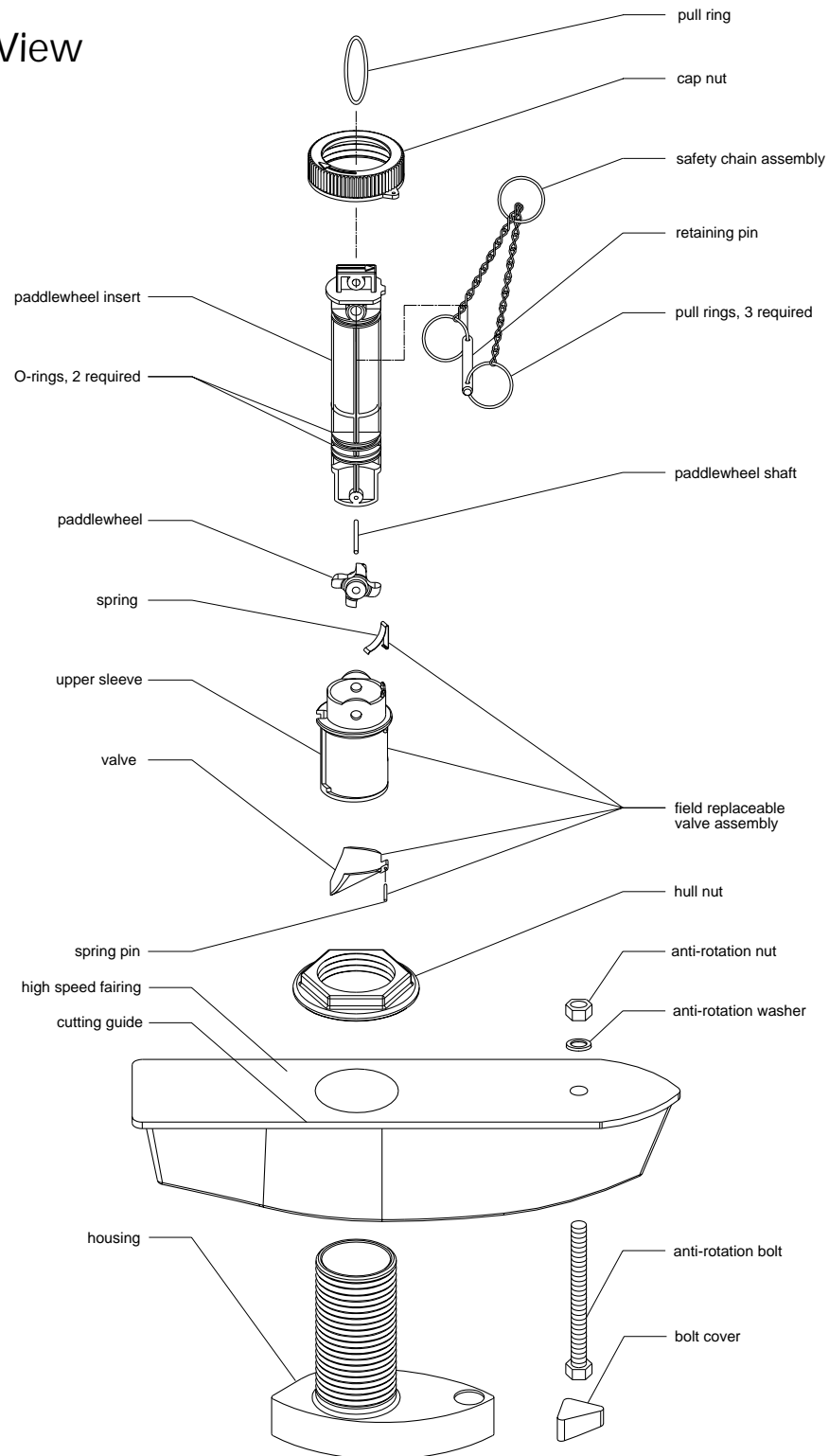

New • THRU-HULL MOUNT • Depth • Speed • Temperature

FREQUENCY AVAILABILITY by HOUSING TYPE						
Ceramic Designation	Beam Width @-3dB	Housing				
		B744V	B744VL	SS544V	B66V	B66VL
50 kHz – C	46°				●	●
120 kHz – B	16°	●	●	●		
120 kHz – C	12°				●	●
120 kHz – M (dual beam)	35° & 14°				●	●
150 kHz – A	19°	●	●	●		
170 kHz – A	12°				●	●
200 kHz – G	8°				●	●
200 kHz – Hlq	8°				●	●
200 kHz – U	11°	●	●	●		
235 kHz – B	11°	●	●	●		
235 kHz – D	7°				●	●
50/200 kHz – A (dual frequency)	45° & 12°	●	●	●		
50 kHz – C & 200 kHz – B (dual frequency)	46° & 13°				●	●

PERFORMANCE DATA					
Frequency <sup>1</sup> – Airmar Piezoceramic Designator <sup>2</sup>	50 kHz – C	120 kHz – B	120 kHz – C	120 kHz – M Dual Beam	
Element Material <sup>3</sup> / Diameter (mm)	PZT/L/ 51	PZT/37	PZT/51	PZT/L/19	PZT/L/55
Beam Width at –3 dB	46°	16°	12°	35°	14°
Q (fr/Δ f @ –3 dB) <sup>4</sup>	18	21	21	9	15
Rated RMS Power (W)	600	300	600	100	600
Voltage Responses: Transmit/Receive <sup>5</sup> (dB)	156/–175	161/–181	166/–174	152/–188	167/–180
Figure of Merit (Insertion Loss) <sup>6</sup> (dB)	–27	–25	–18	–37	–16
Balanced Impedance <sup>7</sup> : Resistance, Rp (ohm) Capacitance, Cp (pF)	280 <sup>12</sup>	260	150	615*	150*
	0	860	1,510	2,200*	4,100*
Series Impedance [R – jX] <sup>8</sup> (ohm)	280 – j0	250 – j40	150 – j20	300 – j310	110 – j50
Acoustic Window Material	Urethane	Urethane	Urethane	Urethane	Urethane

Note: See page m 1 for footnotes.

\* Unbalanced Impedance

**AIRMAR**  
TECHNOLOGY CORPORATION  
m 18  
2000 #17-1205

35 Meadowbrook Drive, Milford, New Hampshire 03055-4613 USA  
Tel (603) 673-9570 • Fax (603) 673-4624 • e-mail: sales@airmar.com

offered by Busse-Yachtshop.com - page 7

New • THRU-HULL MOUNT • Depth • Speed • Temperature

PERFORMANCE DATA					
Frequency <sup>1</sup> – Airmar Piezoceramic Designator <sup>2</sup>	150 kHz – A	170 kHz – A	200 kHz – G	200 kHz – HIq <sup>11</sup>	200 kHz – U
Element Material <sup>3</sup> /Diameter (mm)	PZT/27	PZT/51	BT/51	PZT/51	BT/38
Beam Width at –3 dB	19°	12°	8°	8°	11°
Q (fr/Δ f @ –3 dB) <sup>4</sup>	23	25	29	7	22
Rated RMS Power (W)	200	500	600	600	375
Voltage Responses: Transmit/Receive <sup>5</sup> (dB)	160/–185	172/–184	167/–182	163/–182	164/–185
Figure of Merit (Insertion Loss) <sup>6</sup> (dB)	–27	–17	–16	–19	–22
Balanced Impedance <sup>7</sup> : Resistance, Rp (ohm) Capacitance, Cp (pF)	400	70 <sup>12</sup>	370	865	510*
	550	0	1,120	1,200	1,930*
Series Impedance [R – jX] <sup>8</sup> (ohm)	380 – j80	70 – j0	290 – j150	325 – j420	300 – j250
Acoustic Window Material	Urethane	Urethane	Urethane	Urethane	Urethane

Note: See page m 1 for footnotes.

\*Unbalanced Impedance

PERFORMANCE DATA						
Frequency <sup>1</sup> – Airmar Piezoceramic Designator <sup>2</sup>	235 kHz – B	235 kHz – D	50/200kHz – A		50 kHz – C & 200 kHz – B	
Element Material <sup>3</sup> /Diameter (mm)	PZT/36	BT/51	PZT/44		PZT/L/51	BT/28
Beam Width at –3 dB	11°	7°	45°	12°	46°	13°
Q (fr/Δ f @ –3 dB) <sup>4</sup>	25	16	28	31	18	22
Rated RMS Power (W)	350	600	600	600	600	250
Voltage Responses: Transmit/Receive <sup>5</sup> (dB)	165/–186	169/–185	155/–174	164/–184	156/–175	162/–187
Figure of Merit (Insertion Loss) <sup>6</sup> (dB)	–21	–16	–31	–21	–27	–26
Balanced Impedance <sup>7</sup> : Resistance, Rp (ohm) Capacitance, Cp (pF)	350	370	190	410	280 <sup>12</sup>	510
	410	1,440	720	720	0	560
Series Impedance [R – jX] <sup>8</sup> (ohm)	330 – j70	220 – j180	175 – j40	360 – j130	280 – j0	450 – j160
Acoustic Window Material	Urethane	Urethane	Urethane		Urethane	Urethane

Note: See page m1 for footnotes.