

OPERATING INSTRUCTIONS

Accu-Trainer III AT3 with display Automatic rapid charger for mains or 12V supply for four NiCd/NiMH mignon (AA) / micro (AAA) storage batteries 180-3000 mAh

CE

Dear customer,
Thank you for the trust you have placed in us. You have acquired one of the most powerful, compact and reliable rapid chargers in this class.
Please read through these operating instructions carefully before using the device.

CAUTION!!! Important safety instructions!!

- Keep this device away from children! Risk to life!
- You should avoid operating this device under adverse ambient conditions at all costs. Adverse ambient conditions include: ambient temperatures above 50°C, combustible gases, solvents, vapors, dust, relative air humidity above 80%, and wet conditions.
- The device may be used only in dry, closed rooms.
- If there is any reason to suppose that hazard-free operation is no longer possible, the device must be taken out of service immediately and secured against inadvertent use. Hazard-free operation is no longer to be assumed if the device no longer appears to function, has visible damage, or in the event of damage in transit, or after storage under unfavorable conditions.
- Service and repair – Servicing and repairs may be carried out only by authorized specialists.

Proper use

Proper use is restricted only to the charging of NiCd and NiMH storage batteries.
In the case of other batteries, there is a risk of explosion!

Overview of functions

- Automatic rapid charger for four NiCd/NiMH mignon/micro storage batteries, 180-3000 mAh.
- The charging procedure is started automatically after the batteries have been inserted.
- Four independent charging compartments. Charge current max. 1,3 A per battery with simultaneous charging.
- "Battery full" detection through delta peak voltage detection.
- Maximum charging result – low warming of batteries during the charging procedure, through intelligent temperature controller.
- Automatic switch to trickle charge after end of charging.
- Automatic forming of damaged batteries.
- Quadruple display – simultaneous display of functional and charge state of all batteries in the display.
- Battery capacity measurement.
- Battery analysis function.
- Battery recycling function – the battery is charged until no further increase in capacity can be measured.
- Selective battery choice – via the cursor, the functions for each charging compartment can be set individually.
- Battery defect detection.
- Safety timer (5h) for faulty cells
- Wide-range input for world-wide use (100-240 VAC).
- 12VDC Input (10,5-16V)

Operation

Caution! Charge only NiCd or NiMH batteries. There is a risk of explosion if other batteries are charged!
Environmental warning: Batteries should not be disposed of with domestic waste. Hand in any defective batteries to a public collection point or to your dealer.

Battery analysis

Each charging compartment has an LCD display assigned to it. Running, ascending segments and the numeric capacity display (Ah) provide information about the capacity and the quality of all the batteries, relative to one another. Any cell in a battery pack or group whose capacity value lies clearly below the value of the other cells should be replaced, since the cell with the lowest capacity determines the performance of the battery pack or battery group. The Akku-Trainer III is thus also a battery analyzer. Poor batteries are identified and can be replaced individually, instead of replacing the whole battery pack. This is good for the environment, and saves money.

Charging

As long as no batteries are inserted, the display reads "nob" (no battery). This means that there are no batteries in the charging compartment.
When a battery is inserted, rapid charging starts automatically, and is indicated on the display by ascending segments. During charging a clock symbol and elapsed time are displayed.
After charging has been completed, the "battery full" symbol appears (all segments lit), and the energy index is shown on the display.

Capacity measurement

When the discharge button is pressed briefly, the discharge procedure is triggered. Information about the progress of discharging is provided by descending segments in the battery symbols, and the simultaneous numeric display. The discharged capacity is the measure of the battery capacity. When the end-of-discharge voltage is reached, the measured capacity (Ah) is stored in the memory. The charging procedure is now started automatically.

Reading the capacity

The last measured capacity (last discharge procedure) can be read in the display via the "Capacity check" button, for all batteries simultaneously.

Recycling

By pressing the discharge button for longer (approx. 2 seconds), the battery is discharged and charged repeatedly until no further increase in capacity can be measured. This "training" of the batteries should be carried out from time to time. The recycling procedure can last for several hours.

Forming

Batteries that have been damaged (cell short) are detected on insertion. The forming process (repairing batteries) is initiated automatically, and "For" appears in the display.

In the event of successful forming, the device switches over to charging after 5 minutes. If forming is unsuccessful, "Err" appears in the display; the battery should be disposed of properly.

Overvoltage

Expired batteries are "dried out" inside and have a high natural voltage. This state is detected and is indicated in the display by "bAd". The battery is unusable and should be disposed of properly.

Selecting the charging compartment

Each battery can be selected and dealt with individually, by pressing the button " ? ". The charging compartments are independent of one another.

Other special features of the Akku-Trainer III AT3 with display

Battery-full criteria

Charging takes place according to the -?U method (delta peak voltage detection). This ensures that the batteries are charged to 100%. During charging, the battery characteristics are constantly monitored by the microprocessor, and the charge current is switched off when a 100% charge is reached – not too early, and not too late.

With other charging methods, e.g. using timers, batteries are often overcharged. If batteries are overcharged, they heat up markedly after just a few minutes. This heating as a result of overcharging is one of the most frequent causes of premature failure of batteries.

Optimum charging conditions

In many chargers, power components are located in the vicinity of the battery compartments, and cause so-called "hot spots". These hot spots frequently cause the charge current to switch off prematurely, thus leading to premature and incorrect "battery full" detection.

With this device, an intelligent microcontroller ensures perfect charging behavior. In the development of the device, care was taken that no power components are located in the vicinity of the battery compartments.

Energy index – comparative measurement

The energy index is used to show the relative capacity of all the charged cells compared to each other. This allows for quick analysis of battery packs and thus enables restoration of the initial efficiency, in case individual cells degenerate prematurely.

This is achieved by referencing each cell with the one of highest capacity (energy index 1.00). All the other cells are evaluated relating to this value, e.g. cell 2: EI 0.81, cell 3: EI 0.97, cell 4: EI 0.96.

This example shows that cell 1 is best, cells 3 and 4 only slightly below, but cell 2 is significantly degenerated. In this case cell 2 should be replaced, if it is to be used in conjunction with the other cells.



A comparative measurement is of course only meaningful when done with equal cell types of same nominal capacity.

Operating and display element

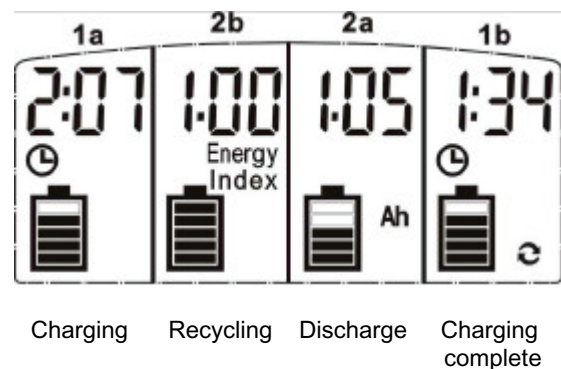
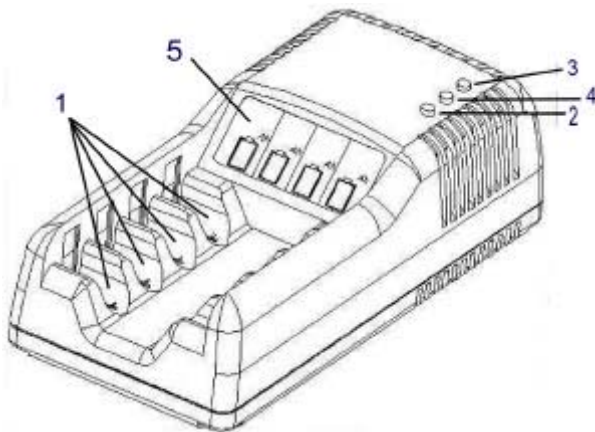
1. Charging compartments for batteries
NiCd / NiMH micro (AAA) and mignon (AA) batteries with a capacity of 180-3000 mAh can be charged. All charging compartments are independent of one another. It is thus no problem to charge both NiCd and NiMH batteries as well as micro and mignon batteries of different capacities simultaneously. The charging procedure is started automatically when the batteries are inserted. See display 1a.
- 1a. Display
- 1b. Display: charging complete
1. Discharge and Recycling button – press briefly to start the discharge function. See 2a. Pressing for longer starts the recycling function. See 2b.
- 2a. Display screen, discharging with numeric value of the capacity that has already been discharged (Ah)
- 2b. Display for recycling – at the end of the recycling procedure, the charged battery capacity is shown numerically. See 1b.
2. Capacity Check button – the last capacity to be measured (last discharge procedure) can be read out.
3. Selective battery choice by pressing the "? " button, the desired battery is selected and marked with a flashing frame. The functions Discharge, Recycle and Capacity Check can now be initiated selectively. If the button is pressed repeatedly until no flashing frame appears in the display any longer, all batteries will be dealt with at the same time.

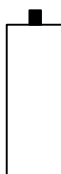

Formatting

For 	Damaged batteries Over a period of 5 minutes, the charger attempts to repair the battery. If successful, charging is started automatically.	Err 	The attempt at formatting was unsuccessful. The battery is defective and must be disposed of properly.	bAd 	The battery is dried out and must be disposed of properly.
--	--	--	--	---	--

Technical specifications

Input voltage:	100 - 240 VAC or 10,5 - 16 VDC
Power consumption:	18 W
Max. charge current per compartment:	1,3 A
Size of plug power pack:	90 x 65 x 95 mm
Size of charging part:	145 x 70 x 45 mm
Weight:	380 g (plug power pack and charger)
Connection lead:	approx. 140 cm (plug power pack to charger)
Connection lead:	approx. 150 cm (12V supply)

We reserve the right to make technical alterations. We assume no liability for typing errors. 08/2003.
 IVT Innovative Versorgungs-Technik GmbH, Dienhof 14, 92242 Hirschau
 Tel: (49) 9622-719910, Fax: (49) 9622-7199120 Info@IVT-Hirschau.de www.IVT-Hirschau.de