

RC435 & RC435i Chartplotters

Owner's Handbook

Document Number: 81236-2
Date: August 2004

About this Handbook

Introduction

This handbook describes the RC435 Chartplotter with external GPS antenna and RC435i Chartplotter with internal GPS antenna. The RC435 and RC435i utilize Satellite Differential (SD) signals for enhanced navigational accuracy.

The RC435 and RC435i GPS Chartplotters are waterproof and therefore can be installed above deck. The equipment is comprised of:

- 6 in Color LCD display with Chart holder compartment for a Navionics® Gold Chart electronic chart card
- Low profile external GPS antenna for the RC435
- Internal GPS antenna for the RC435i

The RC435/435i Chartplotters can output GPS and Waypoint data to operate with other equipment, such as an autopilot or repeater instrument connected via the NMEA 0183 interface. You can also download waypoints and routes to the RC435/435i from an external source.

Note: *This handbook contains important information about installing, using and maintaining your new Raymarine product. To get the best from the product, please read this handbook thoroughly.*

Conventions Used

Throughout this handbook, dedicated buttons are referred to in bold capitals (for example, **ENTER**). Functions, modes of operation and options are shown in normal capitals (for example, LIGHT).

Operating procedures, which may consist of a single key-press, or a sequence of numbered steps, are indicated by a ► symbol in the margin.

When textual data is displayed on screen, any unavailable data is shown as dashes, one per character.

Where procedures refer to *Select*, this implies using the trackpad to highlight a function and then pressing the **ENTER** key.

Important Information

This handbook contains important information on the installation and operation of your new equipment. In order to obtain the best results in operation and performance, please read this handbook thoroughly.

Raymarine's Product Support representatives, or your authorized dealer, are available to answer any questions you may have.

Intended Use

The Raymarine RC435 is a chartplotter display unit with a built-in GPS receiver and external GPS antenna. The Raymarine RC435i version of the chartplotter display contains an internal GPS antenna. Both units are intended for marine navigation purposes on recreational boats.

Warranty

To register your RC435/435i ownership, please take a few minutes to fill out the Warranty registration card at the back of this handbook. It is very important that you complete the owner information and return the card to the factory in order to receive full warranty benefits.

Technical Accuracy

To the best of our knowledge, the information in this handbook was correct as it went to press. However, our policy of continuous product improvement and updating may change specifications without prior notice. As a result, unavoidable differences between the product and handbook may occur from time to time. Raymarine cannot accept liability for any inaccuracies or omissions it may contain.

For the latest product information visit our website:
www.raymarine.com

EMC Conformance

All Raymarine equipment and accessories are designed to the best industry standards for use in the recreational marine environment.

The design and manufacture of Raymarine equipment and accessories conform to the appropriate Electromagnetic Compatibility (EMC) standards, but correct installation is required to ensure that performance is not compromised.

GPS Reception

GPS systems must have a clear horizon-to-horizon view to track satellites. The GPS antenna must be mounted in an open location with a clear, unobstructed view of the sky. Because its GPS antenna is internal, the RC435i should never be mounted below deck or panel (flush) mounted. The optional Panel Mounting Kit listed in the handbook applies to the RC435 with External Antenna only.

Failure to properly mount the chartplotter can result in poor performance.

Safety Notices

CAUTION: Product Installation

This equipment must be installed and operated in accordance with the instructions contained in this handbook. Failure to do so could result in poor product performance, personal injury and/or damage to your boat.

CAUTION: Navigation Aid

Although we have designed this product to be accurate and reliable, many factors can affect its performance. As a result, it should only be used as an aid to navigation and should never replace common sense and navigational judgement. Always maintain a permanent watch so you can respond to situations as they develop.



WARNING: High Voltage

This unit contains high voltages. Adjustments require specialized service procedures and tools available only to qualified service technicians – there are no user serviceable parts or adjustments. The operator should not remove the cover or attempt to service the unit.

Raymarine Products and Services

Raymarine products are supported by a network of Authorized Service Representatives. Raymarine's Technical Services representatives or your local dealer will be available to answer any questions you may have. For information on Raymarine products and services, contact either of the following:

United States Raymarine, Inc.
22 Cotton Road, Unit D
Nashua, New Hampshire
03063-4219 USA
Telephone: 1-603-881-5200
 1-800-539-5539
Fax: 1-603-864-4756

Europe Raymarine Ltd
Anchorage Park
Portsmouth, Hampshire
PO3 5TD England
Telephone: +44 (0) 23 9269 3611
Fax: +44 (0) 23 9269 4642

Or, you may contact us on the World Wide Web at:

www.raymarine.com

© Raymarine Limited 2004

Contents

About this Handbook	iii
Introduction	iii
Conventions Used	iii
Important Information	iv
Intended Use	iv
EMC Conformance	iv
GPS Reception	v
Safety Notices	v
Chapter 1: Overview	1
1.1 RC435 and 435i Chartplotters	1
Display Features and Functions	1
Operating Controls and Display Layout	1
Trackpad and Cursor	2
Dedicated Keys	3
Status Bar	3
Function Bar	3
Pop-Up Menus	4
Database Lists	4
1.2 Satellite Differential System	4
How it Works	5
Availability of WAAS and EGNOS Signals	6
Broadcast Continuation and Accuracy	6
Chapter 2: Installation	7
2.1 Introduction	7
EMC Installation Guidelines	7
2.2 Unpacking and Inspecting the Components	8
Items Missing?	8
Optional Items	8
2.3 Installing the RC435 External GPS Antenna	9
Special Instructions for Installing the RC435i	9
Surface Mounting the External GPS Antenna	10
Pole Mounting the External GPS Antenna	11
2.4 Installing the Chartplotter	12
Bracket Mounting	14
Panel Mounting	14
2.5 Running the Cable	16
Introduction	16
Connectors	16
2.6 System Check and Initial Switch On	19
EMC Conformance	19

	System Check	19
	Initial Switch On	19
	Checking Chartplotter Operation	20
Chapter 3:	Getting Started	21
3.1	Introduction	21
	Simulator	21
3.2	Switching On/Off	22
	Changing the Lighting and Contrast	22
3.3	Simulator Mode	23
3.4	Controlling the Display	24
	Selecting the Display Mode	24
	Moving Around the Chart	26
	Using FIND SHIP	26
	Changing the Chart Scale	27
3.5	Using Navionics Gold Chart Cards	29
	Inserting a Gold Chart Card	30
	Removing a Gold Chart card	30
	Loading the Chart Data	31
	Displaying the Chart Data	32
Chapter 4:	Setting Up	33
4.1	Introduction	33
4.2	System Set Up Parameters	33
	Bearing Mode	35
	Key Beep	35
	Units	36
	Variation	36
	Variation Mode	36
	Date Format	36
	Time Offset	36
	Language	36
	Simulator	37
	Simulated SOG	37
	Simulated COG	37
4.3	Chart Set Up Parameters	38
	Orientation	40
	Plotter Mode	40
	Show Waypoints	41
	Waypoint Symbol	41
	Autozoom	41
	Screen Amplifier	41
	COG Vector	41
	Arrival Circle	41

	Anchor Alarm	42
	XTE Alarm	42
	Select Chart	42
	Chart Text	42
	Chart Boundaries	43
	Safety Contours	43
	Depth Contours	43
	Spot Soundings	43
	Light Sectors	43
	Presentation	43
	Position Calibration	43
4.4	GPS Setup	44
Chapter 5:	Operation	47
5.1	Introduction	47
5.2	Working with Waypoints	47
	Placing a Waypoint	48
	Selecting a Waypoint	50
	Waypoint Data Display	51
	Editing Waypoint Details	52
	Erasing Waypoints	54
	Moving Waypoints	54
5.3	Working with Routes	55
	Creating a New Route	56
	Saving the Current Route	58
	Clearing the Current Route from the Screen	59
	Retrieving a Route from the Database	59
	Displaying Route Leg and Waypoint Information	60
	Erasing or (re)Naming a Route	61
	Route Info	61
	Editing a Route	63
5.4	Following Routes and Going to Target Points	65
	Follow a Route	66
	Reverse a Route	66
	Target Point Arrival	67
	Alter a Route	67
	Going to an Individual Target	69
	Go to a Waypoint	69
	Go to Cursor	70
	Go to a Port	71
	Stop Follow or Stop GoTo	72
5.5	Changing the Display Mode	72
	CDI Display	73

	BDI Display	74
	Waypoint Data	75
	Navigation Data	76
	Time/Date Data	78
5.6	Transferring Waypoints and Routes	80
	Displayed Waypoints	80
	Managing Database Lists	80
5.7	Using Tracks	82
	Setting up a Track	82
	Clearing the Current Track	84
	SmartRoute	84
5.8	Object Information	85
5.9	Using Archives	86
	Archiving a Route	86
	Loading or Deleting an Archived Route	88
	Archiving a Track	89
	Loading or Deleting an Archived Track	90
	Archiving a Waypoint Set	92
	Loading or Deleting an Archived Waypoint Set	93
5.10	Displaying Chart Information	95
	Port Services	95
	Tide Information	97
5.11	Man Overboard (MOB)	103
5.12	Alarms	104
Chapter 6:	Maintenance & Troubleshooting	105
6.1	Maintenance	105
	Routine Checks	105
	Servicing and Safety	105
6.2	Resetting the System	106
6.3	Problem Solving	107
	Troubleshooting	107
6.4	How to Contact Raymarine	108
	On the Internet	108
	Customer Support	108
	In the US	108
	In Europe	110
	Worldwide Support	110
Appendix A:	Specifications	111
	NMEA Data	112
Appendix B:	List of Abbreviations	113
	Index	115

Chapter 1: Overview

1.1 RC435 and 435i Chartplotters

Display Features and Functions

The RC435/435i Chartplotter includes the following features:

- Detailed navigation information from installed Navionics® Gold Chart card
- Positional information from Satellite Differential GPS
- GPS satellite status
- Create, Place, Move, Edit or Erase a Waypoint
- GoTo Waypoint, Port, Facility or Cursor
- Create, Save, Name, Edit or Follow a Route
- Review Route and Waypoint Lists
- Display Tide Heights, Tide Currents, Sun and Moon data
- Display vessel's position, direction and track on-screen
- Convert a track to a route (*SmartRoute*)
- Alarms and Timers
- Man OverBoard (MOB) to navigate back to a missing person or object
- Display and keys illuminated for night-time use

Operating Controls and Display Layout

The chartplotter is operated by means of the following controls:

- A multi-direction trackpad with context sensitive cursor
- Six dedicated and labelled push-buttons

The main navigation display also features:

- Dedicated status panel
- Dynamic function bar
- On-screen pop-up menus
- Database lists for storing waypoints and routes

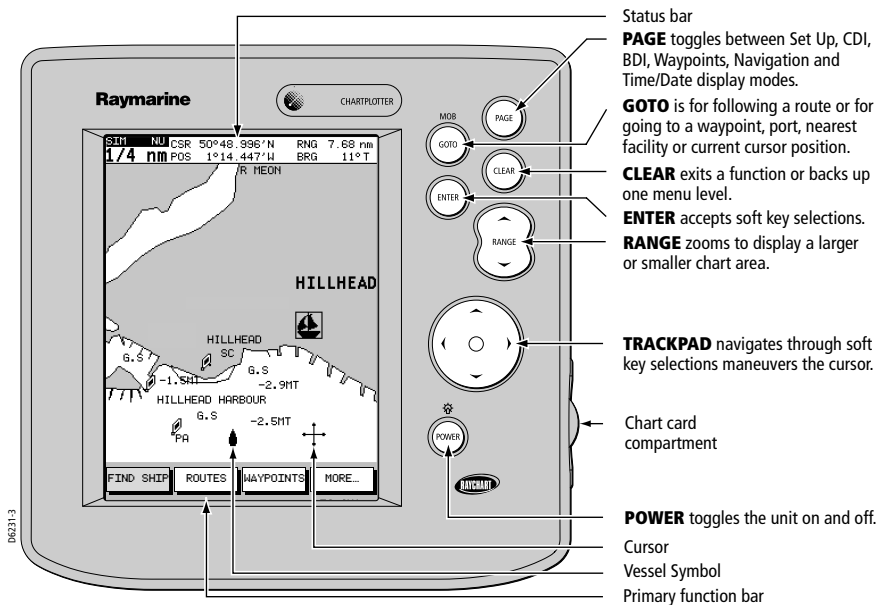

Figure 1-1: RC435/435i Chartplotter Operating Controls

Trackpad and Cursor

On the primary chart display, the trackpad is used to move the cursor horizontally, vertically or diagonally. The cursor is the cross-hair symbol (+) which is used to select a position or item on the chart.

The longer the trackpad is pressed, the faster the cursor moves. The current cursor position (in latitude and longitude) is shown in the status bar at the top of the screen.

The cursor is context-sensitive. Some items on the screen, such as waypoints and chart objects have information associated with them. When the cursor is placed over such objects, this information is displayed in the status bar. Some items may also have options or settings. If available, these are displayed in a function bar at the bottom of the screen.

Note: During many operations the cursor cannot be moved around the screen (while a function bar is displayed, for example) and the cursor is used exclusively for selection. In such cases, three rapid beeps indicate invalid action.

Dedicated Keys

These keys have fixed functions. Some keys can be used in either of two ways:

- **Press:** Press the key briefly and then release it. This method is used for most key operations.
- **Press and hold:** Press the key, keep it pressed for the period of time stated (typically 3 seconds), then release it.

When a dedicated key is pressed, one of the following occurs:

1. The associated operation occurs (for example, change chart scale—**RANGE** key).
2. A pop-up menu is displayed, providing further options.
3. A set of functions is displayed.

As a key is pressed, a single audio beep confirms the key action. If the key-press is not valid for the current screen or mode, three rapid beeps sound to indicate that no response is available. If desired, the key beeps can be turned off as part of your set up procedure (see *Chapter 4*).

Status Bar

On the primary chart display, the status bar at the top of the screen provides context-sensitive information. In general operation this will be the scale of the chart, the position of the cursor (lat. and long) and the range and bearing to the cursor. When the cursor is placed over a dynamic object, the status bar will display information appropriate to that object.

Function Bar

The Function Bar at the bottom of the screen contains a number of functions which change according to the current operation. The functions are grouped into related sets and subsets providing access to the various functions. The primary function bar is displayed when the **ENTER** key is pressed.

The currently selected function is highlighted with a green background.

When a function is invoked, one of the following occurs:

1. The associated operation is performed (for example: GOTO WAY-POINT).
2. A sub-set of functions is displayed.
3. A pop-up menu is displayed, providing further options.

4. The appropriate database list (for example, Route or Waypoint) is displayed.

As with dedicated keys, when the action is invoked, a single audio beep confirms the action. If the selection is not valid, three rapid beeps indicate invalid action. Key beeps can be deactivated as part of the set up parameters (see *Chapter 4*).

Pop-Up Menus

Pop-up menus usually provide various options. When a pop-up menu is on-screen, a set of associated functions is also displayed.

Use the trackpad to select an option from the menu, then use the appropriate function to set the option. For example, the radius of the waypoint arrival alarm can be specified or the selected navigation data can be set on/off.

Database Lists

Waypoints and routes created on the chartplotter are stored in database lists. These lists can be viewed and items selected for editing.

As with pop-up menus, when a database list is on-screen, a set of associated soft keys is also displayed; use the trackpad to select an item from the list, then use the appropriate function to edit the item. For example, a Waypoint or a Route can be erased.

1.2 Satellite Differential System

The RC435/435i GPS Antenna utilizes a satellite differential correction system to improve the accuracy and integrity of the basic GPS signals. Three separate compatible systems currently exist or are in development:

1. Wide Area Augmentation System (WAAS). Developed by the Federal Aviation Administration (FAA) in the USA.
2. European Geostationary Navigation Overlay System (EGNOS). This system is being developed by a European consortium.
3. The MTSAT Satellite-Based Augmentation System (MSAS). Being developed by the Japan Civil Aviation Bureau (JCAB) for civil aviation use.

The area covered by the WAAS system includes the entire United States of America but also extends to a much wider area as detailed below.

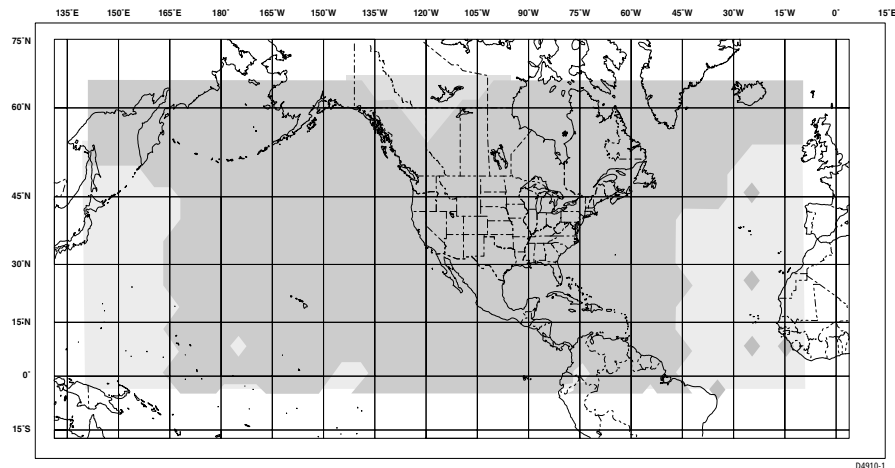

Figure 1-2: WAAS Coverage Map

The combination of the WAAS, EGNOS and MSAS systems will provide global satellite based differential GPS augmentation into the future.

How it Works

The following description is based on WAAS, but the principles apply equally to the EGNOS and MSAS systems.

WAAS comprises the following components:

- Ground Reference Stations across the USA
- Master Stations located at East Coast and West Coast
- Geostationary Satellites located above the equator

The Ground Reference Stations are located at known positions and receive data continuously from GPS. The Ground Reference Stations send their data to the Master Stations which calculate the error of the GPS-received positions and generate correctional data.

The corrected “differential” signals are then sent to the two Geostationary Satellites which broadcast the corrected data on the standard GPS frequency, making it available to the GPS Antenna.

The RC435/435i GPS uses the correctional data transmitted by the Geostationary Satellites to refine the basic GPS positional data for greater accuracy.

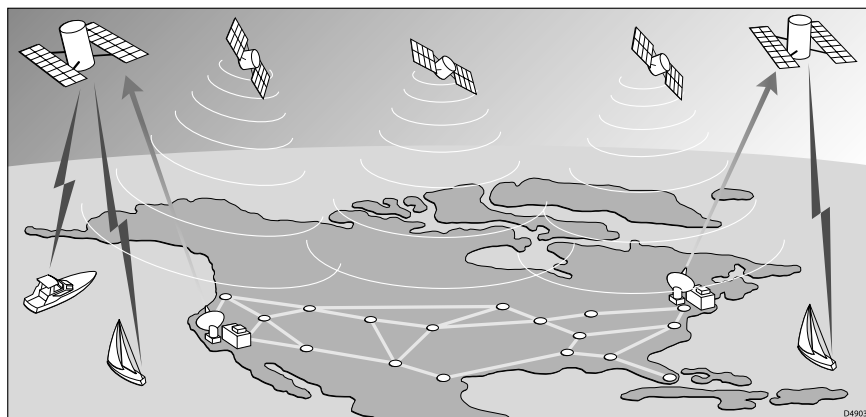

Figure 1-3: The WAAS System

Availability of WAAS and EGNOS Signals

The WAAS system is presently broadcasting in North America.

The RC435/435i Chartplotter is EGNOS compatible. However, at the time of going to print the EGNOS was still under test.

Further information on the WAAS and EGNOS systems can be found at:

www.raymarine.com

Broadcast Continuation and Accuracy

The continuation of the broadcast SD signals is not the responsibility of Raymarine. The navigational accuracy of equipment using these satellite broadcast SD signals is not guaranteed.

Chapter 2: Installation

2.1 Introduction

This chapter provides instructions to assist in planning the installation of the RC435/435i Chartplotter aboard your vessel.

Note: *If you wish to practice using the RC435/435i Chartplotter before installation, you can connect it, via a 1A quick blow fuse, to a 12VDC power supply and operate it using the simulator mode, as described in Chapter 3: Getting Started.*

EMC Installation Guidelines

All Raymarine equipment and accessories are designed to the best industry standards for use in the recreational marine environment.

Their design and manufacture conforms to the appropriate Electromagnetic Compatibility (EMC) standards, but correct installation is required to ensure that performance is not compromised. Although every effort has been taken to ensure that they will perform under all conditions, it is important to understand what factors could affect the operation of the product.

For optimum EMC performance, it is recommended that wherever possible:

- Raymarine equipment and cables connected to it are:
 - At least 3 ft (1 m) from any equipment transmitting or cables carrying radio signals (for example: VHF radios, cables and antennas.)
 - More than 7 ft (2 m) from the path of a radar beam. A radar beam can normally be assumed to spread 20 degrees above and below the radiating element.
- Raymarine specified cables are used. Cutting and rejoining these cables can compromise EMC performance and must be avoided unless doing so is detailed in the installation manual.
- If a suppression ferrite is attached to a cable, this ferrite should not be removed. If the ferrite needs to be removed during installation it must be reassembled in the same position.

Suppression Ferrites

The following illustration shows typical cable suppression ferrites used with Raymarine equipment. Always use the ferrites supplied by Raymarine.

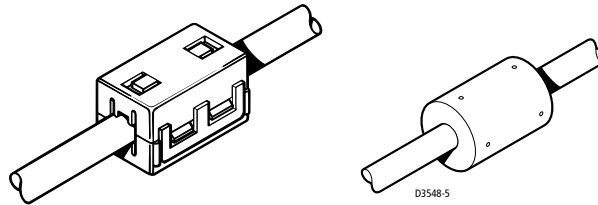

Figure 2-1: Typical Suppression Ferrites

2.2 Unpacking and Inspecting the Components

Unpack your RC435/435i Chartplotter carefully. Retain the carton and packing materials in the event that you need to return the unit for service. Check that you have all the correct system components.

Part Number	Description
E32040	RC435 Chartplotter with External GPS
E33019	RC435i Chartplotter with Internal GPS
E35009	External GPS Antenna for RC435
E32050	RC435/435i Sun Cover
E35005	RC435/435i Mounting Bracket and Mounting Knobs (x2)
E35001	GPS Pole Mounting Kit (RC435 only)
R38024	RC435/435i Power/NMEA Cable

Items Missing?

If any of the above items is missing or damaged, please contact your Raymarine dealer or our Product Support Department to obtain replacements.

Optional Items

You may also order the following accessories from Raymarine:

E32051	RC435 Panel Mounting Kit (Due to internal antenna, RC435i cannot be flush mounted)
--------	---

2.3 Installing the RC435 External GPS Antenna

The RC435 GPS Antenna is designed to receive the signals emitted from the satellites in a direct path.

The GPS Antenna should be mounted in an open location with a clear view of the sky. GPS systems rely on stability to track satellites therefore the height of the receiver is not as important as having a clear horizon to horizon view.

The external GPS Antenna can be mounted on a pole or surface mounted.

When planning the location for the unit, consider finding a convenient pathway for running the cable that connects the GPS Antenna to the display unit. Ideally the cable should be run so that it is hidden from view and, if possible, be in a direct path to the point of connection. It is important to keep the cable separated as far as possible from other shipboard cables to prevent interference.

Note: *Mounting on the mast of a sailboat is not recommended.*

Failure to properly mount the antenna can result in poor performance.

CAUTION:GPS ANTENNA LOCATION

When mounting the GPS Antenna flush to a deck surface, avoid areas where the unit could be stepped on or tripped over.

Special Instructions for Installing the RC435i

Because its GPS antenna is internal, the RC435i should be mounted in an open location with a clear, unobstructed view of the sky.

- **The RC435i should never be mounted below deck.**
- **The RC435i should never be panel (flush) mounted.**

The optional Panel Mounting Kit listed in *Section 2.2, Unpacking and Inspecting the Components*, applies to the RC435 with External Antenna only.

The RC435i must not be flush mounted into the dash of a boat or into a NavPod style instrument housing. The RC435i must be mounted in a relatively open cockpit with its included yoke/trunnion mount bracket. The boat can have a bimini or a dodger, but not a hardtop.

Note: *If you want to flush- or pod-mount the unit, have a hardtop, or are otherwise concerned about giving the upper-rear portion of the unit's chassis a clear view of the sky, you should opt for the standard RC435 with its external antenna.*

Failure to properly mount the chartplotter can result in poor performance.

Surface Mounting the External GPS Antenna

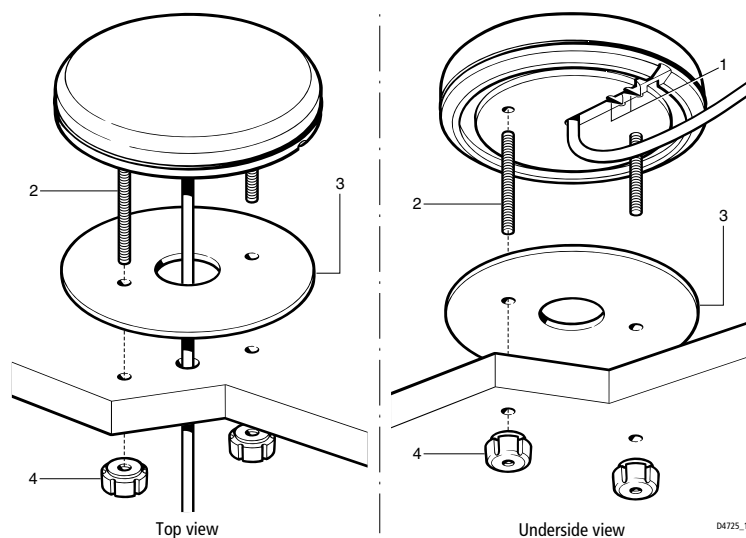

1. Select a suitable area that allows access to the underside of the mounting surface for attaching the mounting hardware.
2. Using the template supplied at the end of the handbook, carefully drill the two 6mm (0.25in) mounting holes.
3. If the cable is to pass through the mounting surface drill the 19mm (0.75in) center hole.
If the cable is to exit from the side of the GPS Antenna above the mounting surface, remove the two plastic tabs (1) obstructing the cable channel.

Note: Failure to remove the plastic tabs from within the cable channel could result in cable damage.

4. Screw the supplied brass studs (2) into the underside of the antenna.
5. Attach the gasket (3) to the mounting surface, ensuring that the holes match and pass the cable through the center hole or the cable exit channel.
6. Carefully position the GPS Antenna, passing the studs through the holes in the mounting surface and secure to the mounting surface using the thumb nuts provided (4).

Pole Mounting the External GPS Antenna

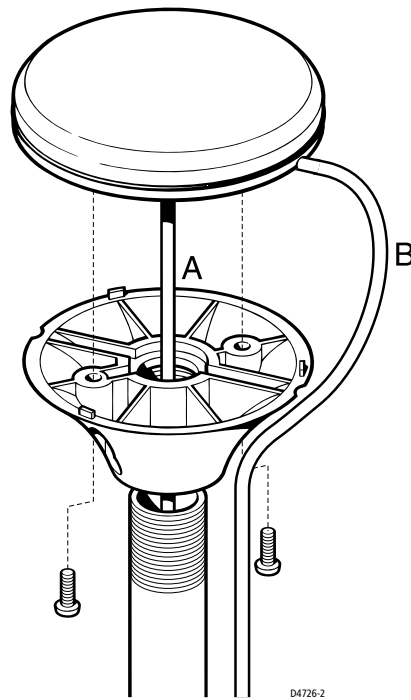

1. Screw the pole mount base to a suitable pole or rail mount bracket, having an industry standard 1 inch 14TPI thread, until secure.
2. Pass the cable through the center hole of the pole mount base (A) or insert the cable into the side exit channel (B).
3. Check that the cable is positioned correctly and secure the GPS Antenna to the pole mount base using the two screws provided. If the cable is to exit from the side of the GPS Antenna through the side channel, remove the two plastic tabs obstructing the cable channel.

Note: Failure to remove the plastic tabs from within the cable channel could result in cable damage.

2.4 Installing the Chartplotter

When planning the installation of your RC435/435i, the following points should be considered to ensure reliable and trouble free operation:

- **Convenience:** The unit should be installed in a convenient position where it can be viewed straight on or with a viewing angle of less than 35°. You may wish to apply power before you install the unit, to determine the best viewing angle prior to fixing. The mounting location should be easily accessible to allow operation of the front panel controls.
- **Access:** There must be sufficient space behind the unit to allow cable connections to the rear panel connectors, avoiding tight bends in the cable. At least 50mm (2in) should be allowed at the right of the chartplotter to enable chart cards to be inserted and removed.
- **Interference:** The selected location should be far enough away from devices that may cause interference, such as motors and generators.
- **Power Source:** The unit should be located near a DC power source. The power cable supplied is 1.5m (5ft), but a longer cable can be used if required. Power must be supplied via a 1A quick blow fuse or circuit breaker. Refer to *Running the Cable* on page 16.
- **Interconnections:** The unit transmits navigation and waypoint data on NMEA and, therefore, can be connected to an NMEA compatible autopilot or compatible instrument repeater(s). The navigation data transmitted by the chartplotter is detailed in *Appendix A*.
- **Environment:** The unit should be protected from physical damage, heat sources and excessive vibration. Although the unit is waterproof, it is good practice to mount it in a protected area away from prolonged and direct exposure to rain and/or salt spray.

When surface mounting the unit to an enclosed compartment, make sure that the compartment is ventilated and drained. Failure to meet this requirement may lead to excessive build up of moisture within the unit, leading to condensation on the screen.

The dimensions of the unit, including the bracket, are shown in *Figure 2-2*.

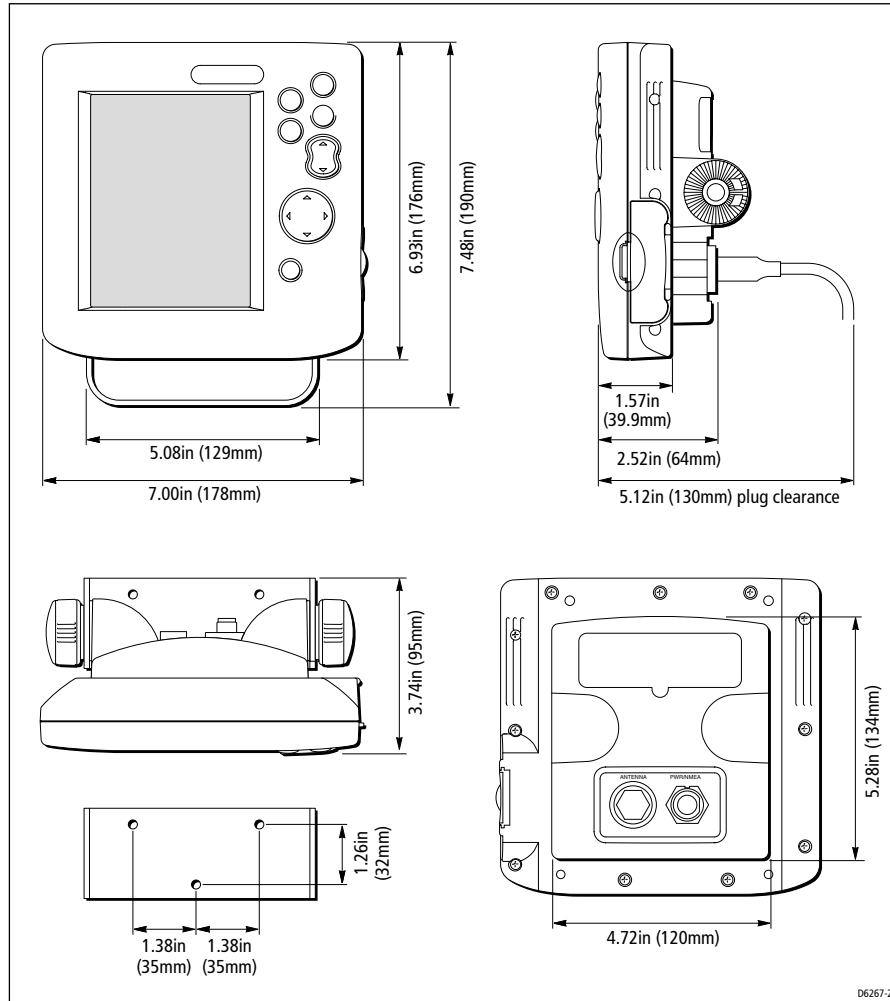

Figure 2-2: RC435/RC435i Dimensions

Bracket Mounting

The display unit can be conveniently mounted on a dash area, chart table, bulkhead or deckhead. Mount the unit as follows:

1. Loosen the mounting bracket knobs and remove the bracket from the display unit.
2. Mark the locations of the bracket screw holes on the mounting surface.
3. Drill the holes where marked.
4. Use the screws supplied to fix the bracket at the marked locations.
5. Fit the unit to the bracket, adjust the display angle and tighten the knobs.

Panel Mounting

CAUTION:

Make sure that there are no hidden electrical wires or other items behind the location before proceeding. Make sure that there is sufficient rear access for mounting and cabling. Allow at least 6cm at the right hand side of the display to enable chart cards to be inserted and removed.

The RC435 can be panel mounted, using the panel-mounting kit (accessory) available from your local Raymarine dealer. A mounting template appears at the end of this handbook.

Note: *The RC435i with Internal GPS antenna cannot be panel (flush) mounted.*

► Panel mount the unit as follows:

1. Check the selected location for the unit. A clear, flat area at least 185mm (7¼ in) wide by 185mm (7¼ in) high, with at least 120mm (4¾ in) of clearance behind the panel, is required.
2. Using the supplied template, trace the unit cut-out and mark the drilling centers for the four securing holes outside of the cut-out area.
3. To provide start holes for removing the cut-out, drill four 10mm ($\frac{3}{8}$ in) holes in each opposing corner.
4. Using a suitable saw, cut along the inside edge of the cut-out line.
5. With the mounting bracket and knobs removed, make sure that the unit fits in the cut-out area.
6. Drill out the four 5mm ($\frac{3}{16}$ in) securing holes as indicated on the template. It is recommended that a 1mm ($\frac{1}{16}$ in) pilot hole is drilled first.

7. Screw the studs into the vacant holes at the rear of the unit, hand tight only.
8. Place the gasket on the unit and slide the unit into the panel cut-out.
9. Secure the unit with the thumb nuts, hand tight only (*Figure 2-3*).

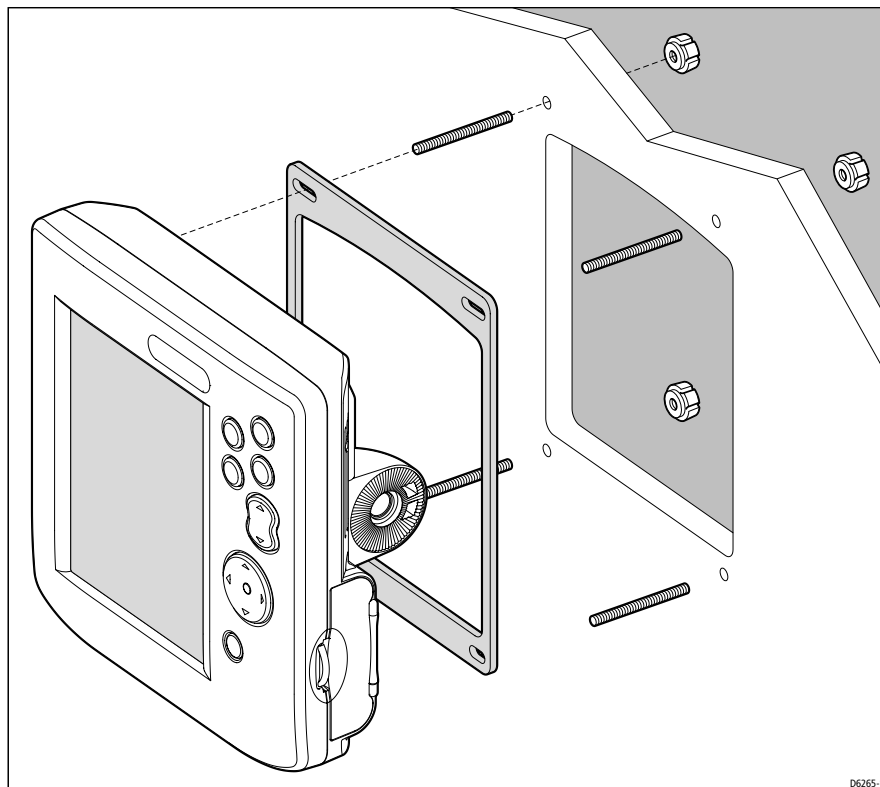

Figure 2-3: RC435 Panel Mounting Arrangement

2.5 Running the Cable

Introduction

The minimum requirements are a power cable and (for the RC435 only) a connection from the GPS Antenna. Additional cables will be required if connecting to other equipment.

Notes: (1) *All Power/NMEA cables should be adequately secured and protected from physical damage and exposure to heat. Avoid running cables through bilges, doorways or close to moving objects or heat sources.*
(2) *Where a cable passes through an exposed bulkhead or deck-head, a swan neck tube should be used.*
(3) *Where the cable will be exposed to the elements, a suitable drip loop should be used.*

Connectors

Antenna Connector

The ANTENNA connector provides power and RF connection to the associated GPS Antenna.

CAUTION:

Do not connect/disconnect the GPS Antenna from the display unit while power is applied. Such action could cause irreparable damage.

- Connect the antenna using the attached cable, as follows:
1. If not already installed, mount the GPS Antenna *Section 2.3*.
 2. Feed the cable through to the rear of the Chartplotter.
 3. Coil up any unused cable in an appropriate safe space out of view. Do not bend the cable tighter than 100mm (4in) radius.
 4. Screw the cable connector fully into its mating connector on the Chartplotter.
 5. Ensure that the protective boot covers the connector.

Note: *If the supplied cable is too short, use an extension cable (Raymarine Part Number E36011), or consult your Raymarine dealer. It is recommended that you use only a single extension cable as each extra connector would reduce signal levels.*

POWER/NMEA Connector

CAUTION:

If you do not have a breaker in your power circuit, you must fit an in-line 1A quick-blow fuse to the positive (red) lead of the power cable. This unit is not intended for use on positive ground vessels.

The POWER/NMEA connector provides for 12VDC power connection and NMEA inputs/outputs using the supplied cable.

The chartplotter is intended for use on vessel's DC power systems operating in the range 10.0VDC to 18.0VDC (in other words, 12V systems, not 24V or 32V systems).

Power connections should be made at a DC power distribution panel through an isolator switch and a 1A circuit breaker or 1A quick blow fuse. All connections must be clean and tight.

The DC power system should be either:

- Negative ground, with the negative battery terminal connected to the vessel's ground
- Floating, with neither battery terminal connected to the vessel's ground

A 1.5m (5ft) power cable is supplied. If a longer power cable run is required, use the supplied power cable to connect to the unit plus a suitable connector block to connect to the extension cable. The supplied power cable cores have a cross-section of 2.0mm² (15 AWG).

Longer power cable runs may require larger wire gauges to minimize any voltage drop in the cable.

If the power cable must be extended, estimate the length of cable between the vessel's main power source and the connector block, then select the correct wire size determined by the distance as indicated below.

Wire size AWG:	16	15	14	12	10	8
Wire size in mm ² :	1.5	2.0	2.5	4.0	6.0	10.0
Maximum Extension (feet):	36	49	65	98	147	230
Maximum Extension (meters):	11.0	15.0	20.0	30.0	45.0	70.0

The DC power and NMEA inputs/outputs should be connected to the **POWER/NMEA** cable at the rear of the chartplotter. The cable colors are detailed below.

Pin	Function	Color
1	Battery positive + (10.0VDC to 18.0VDC)	Red
2	Battery negative –	Black
	NMEA Input (-ve) common	Green
	Not connected	Gray
3	NMEA output (-ve) common	Brown
4	NMEA output (+ve)	Yellow
6	NMEA Input (+ve)	White
	Not connected	Drain/Screen (bare wire)

➤ Connect to the power supply using the power cable supplied:

1. Connect the molded connector to the **POWER/NMEA** connector on the rear chartplotter. Run the free end back to the vessel's distribution panel or to a junction box.
2. Cut the cable to length and connect the red wire (via a 1A quick blow fuse) to the + battery terminal and the black wire to the – terminal.
3. Use a suitable junction box to connect to any NMEA equipment.
4. Cut any unused wires short or insulate and tape back.

If the power connections are accidentally reversed, the system will not function. Use a voltmeter to check that the input power leads are connected with the correct polarity.

2.6 System Check and Initial Switch On

When installation is complete and all connections have been made, re-check the installation before using the system for navigation. If problems occur, refer to *Chapter 6: Maintenance & Troubleshooting*.

EMC Conformance

Always check the installation before going to sea to make sure that it is not affected by radio transmissions, engine starting, etc.

System Check

Before performing the functional test, check that:

- All connections are clean and tight
- All cables are secured and protected

Initial Switch On

To switch on the chartplotter, press the **POWER** key.

If necessary, adjust the lighting and contrast (see *Chapter 4*).

If desired, change the default language settings as follows:

1. Press the **PAGE** key to display the setup function bar.
2. Using trackpad left/right, select the SYSTEM SET UP function and press **ENTER**. The SYSTEM SET UP menu is displayed, listing the parameters and their current settings:

SYSTEM SET UP	
BEARING MODE	TRUE
KEY BEEP	ON
DISTANCE UNITS	nm
SPEED UNITS	KNOTS
DEPTH UNITS	FEET
VARIATION	5°W
VARIATION MODE	AUTO
DATE FORMAT	MM/DD/YY
TIME OFFSET	UTC
LANGUAGE	ENGLISH
SIMULATOR	OFF
SIMULATED SOG	5.0 KTS
SIMULATED COG	340°T

D6247-3

Figure 2-4: System Set Up Menu

3. Using trackpad up/down, select the LANGUAGE option.
4. Using trackpad left/right, select the desired language.
5. Press **ENTER** to return to the setup functions. The chartplotter now uses the selected language.
6. Press **CLEAR** to return to the normal chart screen.

Checking Chartplotter Operation

To confirm that the chartplotter is operating correctly, perform the following checks:

1. Press the trackpad left/right, up/down and check cursor movement and normal scrolling action.
2. Insert a Navionics Gold Chart® card for the area of your vessel. You are asked to select one to use (See *Select Chart* on page 42)
3. Use the **RANGE** key to zoom-in and check that the new chart cartridge data is displayed.
4. Ensure that position data is available; use the **FIND SHIP** function to check that the cursor is fixed on the vessel symbol which is correctly positioned at the center of the chart display, see *Chapter 5: Operation*.

Chapter 3: Getting Started

3.1 Introduction

This chapter provides information and instructions to allow you to start using your RC435/435i Chartplotter. It is intended to help you familiarize yourself with the controls before you start using the chartplotter for routine navigation.

Note: *There is often more than one method of performing a particular task. Normal operating procedures are detailed in Chapter 5. When you are familiar with the system you can adapt these procedures to suit your method of operation.*

Simulator

The Chartplotter includes a *Simulator* mode, which allows you to practice operating your chartplotter without live GPS data. *Section 3.3, Simulator Mode* describes how you can switch to this mode. Simulator mode can be used in the following situations:

- Before the chartplotter has been installed on your vessel. Connect the Chartplotter unit to a 12V DC power supply, fused at 1A, connecting the red core from the power lead to positive (+) and the black core to negative (-); see *Chapter 2* for full details.
- Once the chartplotter has been installed on your vessel and while in a marina or otherwise at anchor.

3.2 Switching On/Off

- To turn the chartplotter unit on, press the **POWER** key. The keys illuminate, the unit beeps and the Raychart logo is displayed, followed by this warning:

WARNING:

THE ELECTRONIC CHART IS AN AID TO NAVIGATION DESIGNED TO FACILITATE THE USE OF AUTHORISED GOVERNMENT CHARTS, NOT TO REPLACE THEM. ONLY OFFICIAL GOVERNMENT CHARTS AND NOTICES TO MARINERS CONTAIN ALL INFORMATION NEEDED FOR THE SAFETY OF NAVIGATION AND, AS ALWAYS, THE CAPTAIN IS RESPONSIBLE FOR THEIR PROPER USE.

When you have read and understood the warning, press the **ENTER** key.

If this is the first time that the chartplotter has been switched on and no chart card is installed, the display shows the background world map at Lat. 0°/Lon 0°.

- To turn the unit off, press and hold the **POWER** key. A countdown timer is displayed. Keep holding the key until this reaches zero when the unit will power off.

Changing the Lighting and Contrast

You can change the level of backlighting and contrast for the screen. The backlights for the keys are constantly lit for safety. To change the lighting and contrast:

1. Press the **POWER** key to display the lighting controls.

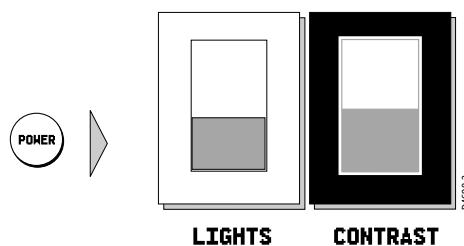

The **CONTRAST** control is highlighted with a dark outline.

2. Press the trackpad left/right to select the **LIGHTS** function.

3. Press the trackpad top/bottom to increase or decrease the lighting to one of four levels. You can press and hold the trackpad to change the setting more rapidly. The lighting level is adjusted as you change the setting.
4. Press the trackpad right to select the CONTRAST control. There are 16 contrast levels. Adjust the setting as for lighting to select the best viewing level.
5. Press **CLEAR** to return to the chart screen, with the new lighting and contrast levels retained.

Note: *The CONTRAST and LIGHTS settings are retained when the unit is powered down. However, if you set the LIGHTS value to less than 60% brightness, the setting automatically returns to 60% brightness when the unit is next turned on. This ensures that the screen is not too dim to view.*

3.3 Simulator Mode

When simulator mode is started, your initial simulated position is wherever the cursor was last positioned. To practice using the chartplotter in a particular chart area, use the trackpad to pan to that area, then switch simulator ON. When in Simulator mode, a flashing SIM indication is displayed in the top left hand corner of the chart screen.

Note: *If real position data is available and the simulator is active, simulated data takes precedence. On power-up the simulator defaults to its previous setting on power-down.*

CAUTION: Simulator Mode

Care should be taken to determine the desired mode on power-up. Simulated data should never be used for navigational purposes.

- To view a chart image using simulated data:

1. Press the **PAGE** key to display the SET UP function bar:

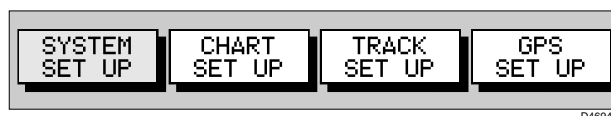

2. Press trackpad left/right to highlight SYSTEM SET UP and press **ENTER** to display the System Set Up menu.
3. Use trackpad up/down to highlight the SIMULATOR option.
4. Use trackpad left/right to select ON.

5. If necessary, use trackpad up/down to highlight, in turn, the SIMULATED SOG and COG options and trackpad left/right to set as desired. Speed is set in 1Kt intervals and Course in 1° intervals.
6. Press **CLEAR** twice to return to the chart screen.
7. A flashing SIM indicator appears at the top left of the chart screen.

3.4 Controlling the Display

This section describes how to:

- Change the display mode
- Move around the chart by panning the display, changing the chart center and changing the chart scale

Selecting the Display Mode

Use the **PAGE** key to select the display mode. Select the following modes by repeat presses of the **PAGE** key as listed below and as shown overleaf:

- Set Up functions (see *Chapter 4*)
- Course Deviation Indicator (CDI)
- Bearing & Distance Indication (BDI)
- Waypoint data
- Navigation data
- Time/Date data
- Return to Chart Display

Note: *The setup function bar is displayed when first entering a screen, press **CLEAR** to hide this bar.*

Note: *Press **GOTO** to return to normal Chart display at any time*

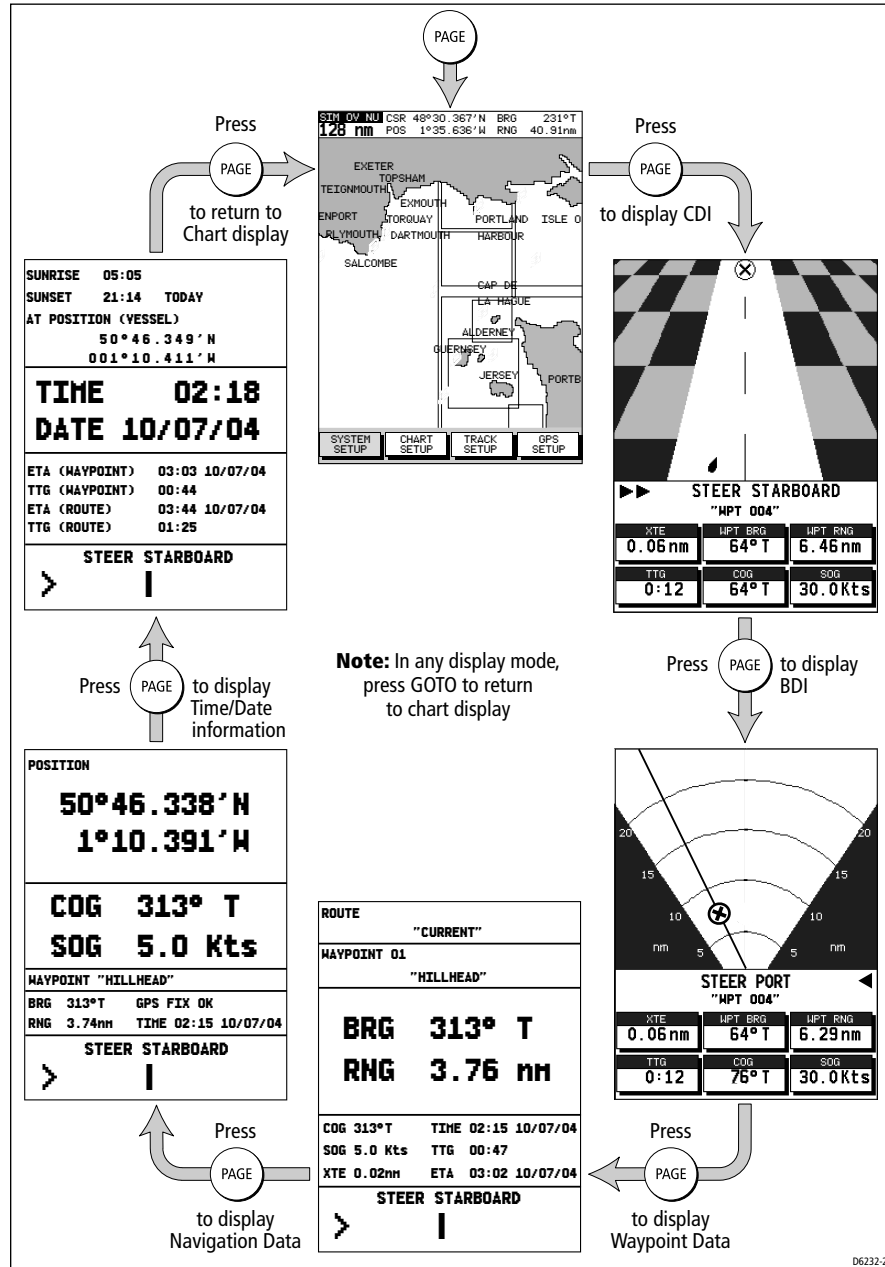

Figure 3-1: Display Modes

Moving Around the Chart

The most common use of the chartplotter is to show your vessel's current location.

In the default North-Up orientation (shown as NU in the status box at the top of the display), the vessel moves in relation to the screen. You will need to reposition the chart if your vessel moves out of the area currently displayed, or if you wish to examine or place waypoints in another area.

You can also *home* the cursor to the vessel using the FIND SHIP function. "Homing" locks the vessel to the cursor and updates the display such that the chart is re-drawn so that the vessel is always on screen. See *Using FIND SHIP* below.

There are three ways in which you can reposition the chart:

- Use the trackpad to move the cursor to the edge of the chart; the chart pans across. This method is useful if the area you wish to see is just off screen.
- Automatically re-center the vessel using the FIND SHIP function.
- Change the chart scale using the **RANGE** key to zoom out and in to a new area. This method is useful if the area you wish to see is some distance away.

Using FIND SHIP

FIND SHIP is used to re-draw the chart with the vessel at its center and the cursor homed on the vessel.

► To center the vessel:

1. From chart mode, press **ENTER**; the primary function bar is displayed:

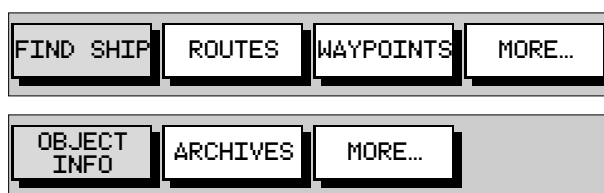

2. Select FIND SHIP; the following actions are performed:
 - The chart is re-drawn with the vessel's position in the center.
 - The cursor is homed onto the vessel position and moves with it.

- When the vessel moves near the edge of the chart window, the chart is redrawn with the vessel at the center and the cursor homed on the vessel.
 - While homed, the status bar indicates position, SOG and COG.
 - If SCREEN AMPLIFIER is enabled, the screen displays the vessel offset from center, to increase forward visibility, see *Chapter 4: Setting Up*.
3. To release the cursor from homed mode press the trackpad to move the cursor away from the vessel's current position. The status bar shows the cursor position, range and bearing from the vessel.

Changing the Chart Scale

The **RANGE** key changes the chart scale so that a larger or smaller area is shown on the available cartography.

Plotter mode is available to allow you to zoom into a smaller area, even when no chart data is available for that scale. To enable plotter mode, see *Chapter 4: Setting Up*.

You can change the chart scale for two purposes:

- To see either a smaller area (in more detail) or a larger area (in less detail)
- To move the display to another area of the chart, by zooming out to a small scale chart, then zooming in to another location

Each time you press the **RANGE** key, the chart scale changes to the next available setting. The Status Bar at the top left-hand side of the screen indicates the distance, from top to bottom of the display, in nautical miles.

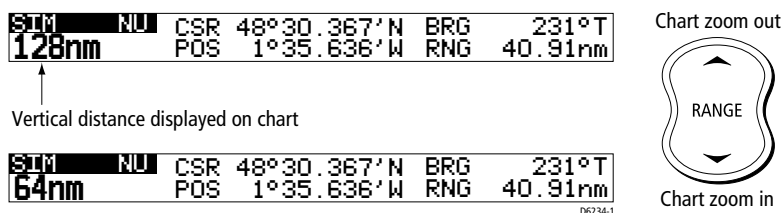

- For rapid scale change, press and hold the desired arrow on the **RANGE** key.

The distance indicator at the left-hand end of the status bar is updated whenever you change the chart scale.

➤ To zoom in to a more detailed chart:

1. Use the trackpad to position the cursor in the area you wish to see in more detail and press the bottom of the **RANGE** key to zoom in. The section of the chart around the cursor is enlarged to fill the screen with the chart showing more detail. The cursor is now positioned in the center of the screen.
2. If further chart enlargement is available using the current chart card you can press the bottom of the **RANGE** key to zoom in again, repositioning the cursor first if needed. An area of further chart detail is indicated by a box around the area.

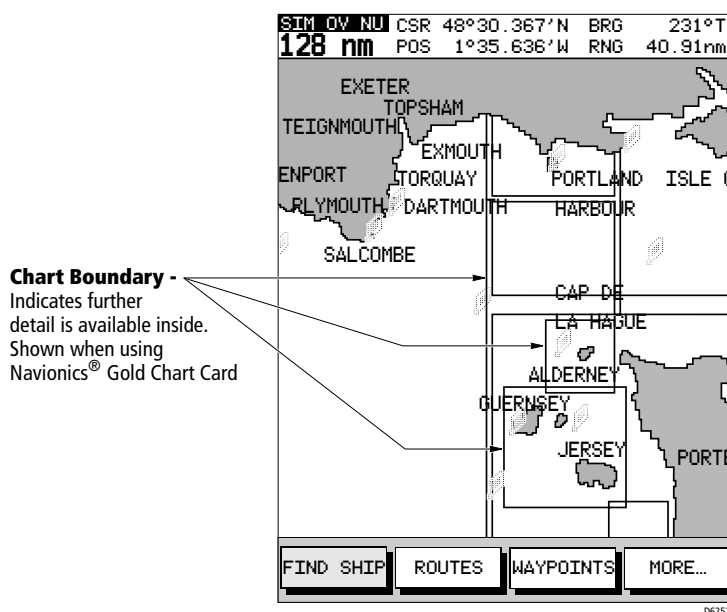

3. In normal operation, the unit will allow you to zoom in as far as the chart detail allows. By selecting PLOTTER MODE in CHART SETUP you can “overzoom” beyond that of the chart card and the vessel, waypoints, routes and tracklines will be displayed without cartography.
- To zoom out to a less detailed chart, press the top of the **RANGE** key as many times as desired.

3.5 Using Navionics Gold Chart Cards

The chartplotter has a built-in world map that can be used for route planning. Most areas (these are shown with chart box boundaries) are covered at a range of approximately 512nm as shown on the Status Bar at the top of the screen.

To use the chartplotter as a navigation aid, charts with detailed information for the area you wish to navigate are required. The charts are available on Navionics Gold Chart cards, each of which can store up to 20 charts in an electronic format.

A Gold Chart card provides an appropriate level of detail for a given geographic area and scale; this data can be displayed down to a range of $\frac{1}{8}$ nm on the screen (height) if the data is available.

To obtain Navionics Gold Chart cards, contact your local dealer or visit www.navionics.com or www.navionics.it to find the dealer nearest you.

Call Navionics toll free from anywhere in North America at:
1-800-848-5896.

Outside of North America, contact your local dealer or:
Navionics S.p.A.
Tel: (+39) 0584 961696
Fax: (+39) 0584 961309

Inserting a Gold Chart Card

CAUTION:

To prevent the ingress of water and consequent damage to the unit, ensure that the chart card door is firmly closed. This can be confirmed by an audible click.

- To insert a Gold Chart card, refer to *Figure 3-2*:
 1. Check that you are using the correct Gold Chart card for the desired area.
 2. Open the chart card door on the right-hand side of the unit.
 3. Insert the card as shown with the smooth edge of the card outermost.
 4. Gently press the card home. If inserted correctly the card release button will move outwards as the card is inserted. If this is not the case, flip the card and retry.
 5. To prevent the ingress of water, close the chart card door and press firmly until an audible click is heard.

Removing a Gold Chart card

CAUTION:

DO NOT use a metallic instrument, e.g. a screwdriver or pliers, to aid removal, as doing so can cause irreparable damage.

- To remove a Gold Chart card:
 1. Open the chart card door.
 2. Gently press the card release button.
 3. Grip the card and pull to remove it from its slot.
 4. To prevent the ingress of water, close the chart card door and press firmly until an audible click is heard.

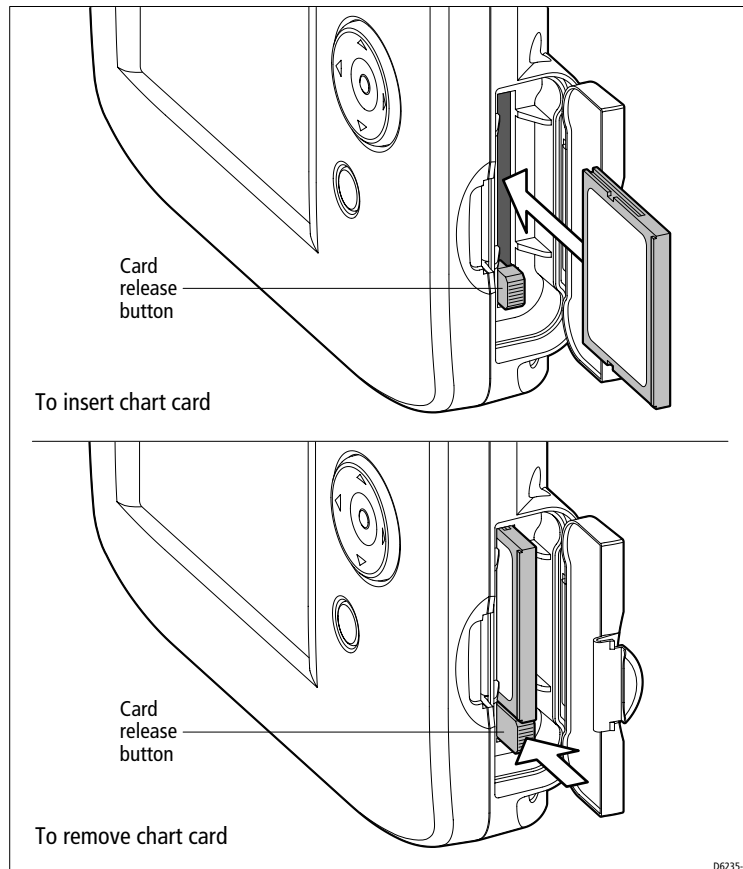
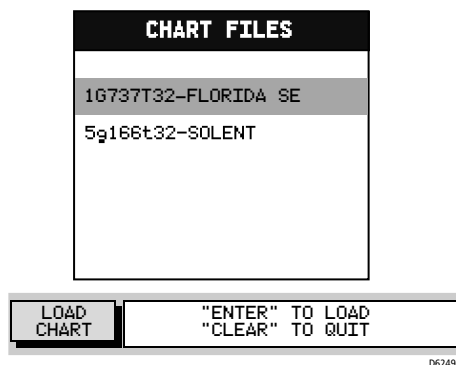

Figure 3-2: Insertion and Removal of Gold Chart Cards

Loading the Chart Data

A Gold Chart Card can hold multiple chart area portfolios. When the flash card is inserted for the first time and the display powered on the following is displayed.



Note: *Only one chart portfolio can be loaded from the Gold Chart Card to the display memory at a time.*

Use the trackpad up/down to select the desired chart and press **ENTER** to load it into the chartplotter's memory.

If a different portfolio is desired this can be accessed by the SELECT CHART option (*see Select Chart on page 42*).

Displaying the Chart Data

The new chart data will be displayed when you move the cursor into an area covered by the new chart.

The boundary of each chart is defined by a box or rectangle. (You can switch off the chart boundaries display as part of chart set up described in *Chapter 4: Setting Up*).

Chapter 4: Setting Up

4.1 Introduction

When you have installed your system and are familiar with its basic operation, you can set it up to operate according to your preferences.

This is achieved using the function controls that are displayed when the **PAGE** key is pressed. These settings can be changed at any time.

When your preferences are set, they remain until they are reset and are retained even when the unit is powered off.

This chapter covers the following topics:

- System parameters and default settings
- Chartplotter-specific parameters and default settings
- GPS status and default settings

The set up parameters are selected via three soft keys:

- **System Set Up:** controlling overall functionality
- **Chart Set Up:** controlling the chartplotter functions, including way-point information and vectors
- **GPS Set Up:** displaying the GPS Antenna status

Note: *The additional TRACK SET UP function is covered in Chapter 5: Operation.*

This section provides instructions for displaying and changing the factory default values to your preferences. The following sections list the parameters with their possible settings and describe the function of each parameter in turn.

4.2 System Set Up Parameters

► To set the System default parameters:

1. From chart mode, with no function bar displayed, press the **PAGE** key to display the SET UP function bar:

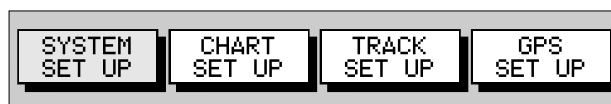

- Use trackpad left/right to highlight SYSTEM SET UP and press **ENTER** to display the System Set Up menu:

SYSTEM SET UP	
BEARING MODE	TRUE
KEY BEEP	ON
DISTANCE UNITS	nm
SPEED UNITS	KNOTS
DEPTH UNITS	FEET
VARIATION	5°W
VARIATION MODE	AUTO
DATE FORMAT	MM/DD/YY
TIME OFFSET	UTC
LANGUAGE	ENGLISH
SIMULATOR	OFF
SIMULATED SOG	5.0 KTS
SIMULATED COG	340°T

D6247-3

Figure 4-1: System Set Up Menu

- Use trackpad up/down to move the highlight up or down the list.
- When the desired parameter is highlighted, use trackpad left/right to step through the settings.
- When the desired values have been chosen, press **ENTER** to implement the change and return to the set up function bar.

Note: *Settings are not saved until the ENTER key is pressed.*

- Press **CLEAR** to clear the function bar and return to normal operation.

Note: *To return all settings to their original factory settings, perform a factory reset as described in Chapter 6.*

The table below lists the System menus and their options, shows the factory default settings and provides space to make a note of personal settings. Each parameter is described in the following subsections.

Menu Item	Options	Factory Default	New Setting
BEARING MODE	MAGnetic/TRUE	TRUE	
KEY BEEP	OFF/ON	ON	
DISTANCE UNITS	NAUTICAL MILES (nm) KILOMETERS (km) STATUTE MILES (sm)	NAUTICAL MILES	
SPEED UNITS	KNOTS KILOMETERS PER HOUR (KPH) MILES PER HOUR (MPH)	KNOTS	
DEPTH UNITS	METRES FEET FATHOMS	METRES	
VARIATION	30°W to 30°E (1° steps)	0.0°E	
VARIATION MODE	MANUAL AUTO	AUTO	
DATE FORMAT	DD/MM/YY or MM/DD/YY	DD/MM/YY	
TIME OFFSET	UTC or local offset value up to 13 hours in 1 hour steps	UTC	
LANGUAGE	Multi Language	ENGLISH	
SIMULATOR	OFF/ON	OFF	
SIMULATED SOG	00Kt to 99Kt in 1Kt steps	00Kt	
SIMULATED COG	000° to 359° in 1° steps	000°	

Bearing Mode

The mode (MAGnetic or TRUE) of all bearing and heading data displayed. This is indicated by M or T in the BRG or COG field of the Chart status bar.

Key Beep

This setting controls audible feedback resulting from operation of the keys.

Note: *Alarms remain active.*

Units

This sets the units for distance, speed and depth. This setting will be used to display all data. However, the distance units do not affect the chart scale, which is always in nautical miles.

Variation

The variation value is the difference between True and Magnetic direction data for heading or bearing values. The Magnetic value is derived from True by applying the user selected value of variation.

The variation is set in 1° steps to 30° East or West. Press trackpad right to move the value eastward, or left to move it westward. The selected value is retained when the unit is switched off. The Default value is zero.

Note: *Variation can only be changed if the VARIATION MODE is set to MANUAL*

Variation Mode

This can be set to AUTO or MANUAL. In AUTO mode, the RC435/435i automatically calculates and sets the magnetic variation. Set this to MANUAL to enter your own value.

Date Format

Set the preferred date format (DD/MM/YY or MM/DD/YY). The selected setting is retained when the unit switched off. The Default is DD/MM/YY.

Time Offset

To display local time, use the trackpad to change from UTC (Universal Time Constant, also known as GMT) to the desired time offset. This can be up to ±13 hours, in 1 hour steps. The default is UTC.

Language

Select the language in which information is to be displayed. The selected language is used for screen text, labels, menus and options. Chart text, provided by the chart card, is not affected.

Simulator

The simulator enables operation of the RC435/435i Chartplotter without data from external sources. The options are ON or OFF.

When ON is selected the simulator generates position, SOG and COG data and uses the simulated data instead of any real data. A flashing SIM status indicator is displayed in the left hand corner of the Status Bar at the top of the screen.

Note: *The simulated data overrides any real data that the display unit is receiving from externally connected equipment.*

The position is initially the position of the cursor when the simulator is switched on and the SOG and COG are as selected by the user. The position is updated to reflect the SOG and COG. See *Simulated SOG* and *Simulated COG* below.

If a GOTO or Follow is started, the simulator does not use the selected value of COG but, instead, generates a value of COG that simulates the navigation function in progress. When GOTO or Follow is stopped, the user selected value of COG is used.

Simulated SOG

Use horizontal movements of the trackpad to adjust the value of SOG which is adjustable in 1 knot intervals from 00 to 99.

The Default value is zero and the selected value is retained on power down.

If the simulator is switched OFF, the value is shown as dashes and no adjustment is possible.

Simulated COG

Use horizontal movements of the trackpad to adjust the value of COG which is adjustable in 1° intervals from 000° to 359°. It wraps around from 000 to 359 and from 359 to 000.

The Default value is zero and the selected value is retained on power down.

If the simulator is switched OFF, the value is shown as dashes and no adjustment is possible.

4.3 Chart Set Up Parameters

The CHART SET UP function allows the chartplotter to be set up according to your system configuration and your personal preferences.

► To set the Chart default parameters:

1. Press the **PAGE** key to display the SET UP function bar:

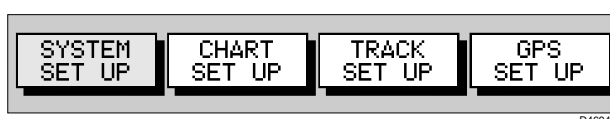

2. Use the trackpad left/right to highlight the CHART SET UP function and press **ENTER** to display the Chart Set Up menu:

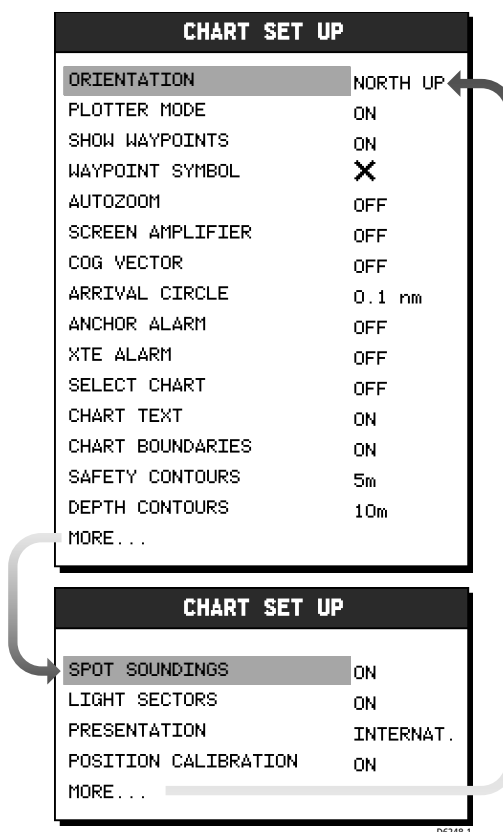

Figure 4-2: Chart Set Up Menu

3. Use trackpad up/down to highlight the desired parameter, then use trackpad left/right to select the desired setting.

Note: *There are two screens for Chart Set-up. Scroll past MORE... to access the other screen.*

4. When the desired values have been set, press **ENTER** to clear the menu and return to the set up function bar.
5. Press **CLEAR** to return to the normal display.

The table below lists the Chart Set up parameters and their options, shows the factory default setting and provides a space to make a note of the new default setting.

Parameter	Options	Factory Default	New Setting
ORIENTATION	NORTH UP COURSE UP HEAD UP	NORTH UP	
PLOTTER MODE	OFF/ON	ON	
SHOW WAYPOINTS	OFF/ON	ON	
WAYPOINT SYMBOL	FISH, SKULL, ANCHOR or X	X	
AUTOZOOM	OFF/ON	ON	
SCREEN AMPLIFIER	OFF/ON	ON	
COG VECTOR	OFF/ON	OFF	
ARRIVAL CIRCLE	0.01nm, 0.05nm, 0.1nm, 0.5nm	0.1nm	
ANCHOR ALARM	OFF, 0.01nm, 0.05nm, 0.1nm, 0.5nm	OFF	
XTE ALARM	OFF, 0.01nm, 0.05nm, 0.1nm, 0.3nm, 0.5nm	OFF	
SELECT CHART	OFF/LOAD CHART	OFF	
CHART TEXT	OFF/ON	ON	
CHART BOUNDARIES	OFF/ON	ON	
SAFETY CONTOURS	OFF/2m/5m/10m/ 20m	2m	

Parameter	Options	Factory Default	New Setting
DEPTH CONTOURS	OFF/5m/10m/20m/ ALL	5m	
SPOT SOUNDINGS	OFF/ON	ON	
LIGHT SECTORS	OFF/ON	ON	
PRESENTATION	INTERNATIONAL U.S.	INTERNATIONAL	
POSITION CALIBRATION	OFF/ON	OFF	

Orientation

The chart orientation is normally North Up, but can be changed to Course Up or Head Up. The selected mode is always shown in the inverse video Mode Indicator in the top left hand corner of the Status Bar at the top of the display in the form NU (North Up), HU (Heading Up) or CU (Course Up). The orientation modes function as follows:

- **North Up:** The chart is displayed with north upwards. This is the default mode and is the only mode available if there is no COG data.
- **Course Up:** The chart is rotated such that the currently selected course (bearing to the target waypoint) or, if no navigation function is taking place, the current COG value is shown upwards. To update the Course Up reference while Course Up is the current mode, re-select COURSE UP from the set up menu. If a new course is selected (a new target waypoint, for example), the chart displays the new course upwards.
- **Head Up:** The chart is displayed with the vessel's current COG upwards. As the heading changes the chart rotates periodically to maintain orientation.

Note: *Head Up and Course Up modes are dependent upon a valid GPS fix.*

Plotter Mode

Plotter mode allows the user to zoom in beyond the level of cartography and continue to use plotter functions. The selected setting is retained when unit switched off.

Show Waypoints

This option controls whether or not the waypoints are shown on the Chart display, with their appropriate symbols. The active waypoint, and waypoints in the current route, are always shown.

Waypoint Symbol

This option allows selection of the symbol for waypoint display. The selected symbol is used for subsequent waypoints. Existing waypoints are not affected. The selected symbol is retained when the unit switched off.

Autozoom

When autozoom is enabled, initializing any navigation function or selecting FIND SHIP activates Autozoom. When active, this selects the chart range and position such that the vessel and the target waypoint are both on screen but at the largest scale possible. Moving the cursor off the vessel, or changing scale, deactivates Autozoom.

Autozoom will not zoom in beyond the largest cartographic scale (unless Plotter Mode is activated). When in MOB mode, Autozoom is selected automatically and will zoom in as far as possible, irrespective of the selection of Plotter Mode.

Screen Amplifier

Screen amplifier mode makes best use of the screen by positioning the vessel on the screen so as to increase forward visibility. The screen amplifier is only active when the cursor is “homed” on the vessel.

COG Vector

When ON, a vector line from the vessel is drawn in the direction of COG. This line extends to the edge of the screen. If COG is not valid, no line is drawn. The selected setting is retained when the unit switched off.

Arrival Circle

The selected value is used as the arrival circle radius. When approaching the target waypoint, this is the distance at which the arrival alarm sounds. The selected setting is retained when unit switched off. Arrival criteria are met when the arrival circle is entered or a line perpendicular to the desired track and passing through the waypoint is crossed.

Anchor Alarm

The selected value is used as the anchor alarm distance. If the vessel moves outside of the selected distance from its position (at the time that the alarm was enabled) the alarm sounds and an alarm message is displayed.

To silence the alarm, press any key. This removes the warning and resets the distance. The alarm will not be triggered again unless the vessel moves the selected distance from its position (at the time that the alarm was turned off). The alarm is set to OFF on power up.

XTE Alarm

The selected value is used as the cross track error limit. The alarm is triggered when the cross track error exceeds the selected limit when a GOTO or a Route Follow is in progress and an alarm message is displayed.

Select Chart

Use SELECT CHART to access different charts from the same Gold Card.

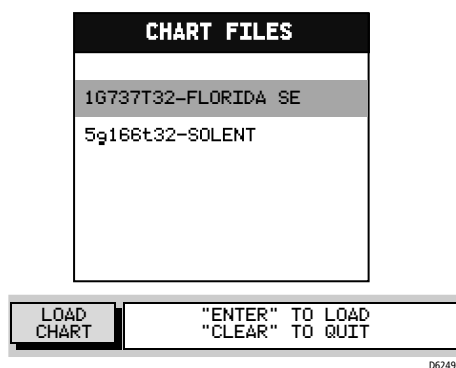

Use the trackpad up/down buttons to select the desired chart and press **ENTER** to load this as the active chart.

Note: *Only one chart can be active at any one time.*

Chart Text

When ON, Chart text (such as place names) are shown on the screen. The selected setting is retained when the unit switched off.

Chart Boundaries

When ON, Chart boundary lines are shown on the screen. The selected setting is retained when the unit switched off.

Safety Contours

Set to display safety contours of less than 2, 5, 10 and 20 meters or set to OFF. The selected setting is retained when the unit switched off.

Depth Contours

Set to display depth contours of 5, 10 and 20 meters, set to ALL to show all contours or set to OFF. The selected setting is retained when the unit switched off.

Spot Soundings

When ON, spot soundings are displayed. The selected setting is retained when the unit switched off.

Light Sectors

When ON, light sectors are displayed. The selected setting is retained when the unit switched off.

Presentation

Set to display navigation mark in either INTERNATIONAL or US symbology. The selected setting is retained when the unit is switched off.

Position Calibration

When ON, all position data is offset from WGS 84 by the value of the selected calibration. The selected setting is retained when the unit switched off. The default calibration offset is zero.

► To perform position calibration:

1. Use the trackpad to select POSITION CALIBRATION.
2. Move the trackpad horizontally.

The menu is removed and a single function and help text are shown:

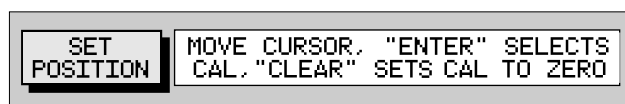

D4713-1

3. Using the trackpad, set the desired offset value. The distance and bearing of cursor from vessel is displayed in the Status Bar as BRG and RNG.
4. Press **CLEAR** to reset the value to zero and return to the Chart Set Up menu.

—or—

Press **ENTER** to confirm the selected offset value. You are returned to the Chart Set Up menu with POSITION CALIBRATION set to ON. Position data is followed by “(c)” to indicate that the calibration offset has been set.

An offset of 2nm or less is applied to all position data equal to the range and bearing between the WGS 84 position and the position entered.

Note: Pressing **ENTER** with a selected offset of more than 2nm gives a warning message which is cleared on any key press. The Calibration Set Up mode maintains and the user can either reselect an acceptable offset or press **CLEAR** to reset the value to zero and return to the Set Up menu.

4.4 GPS Setup

The GPS set up page provides information for the status of the tracked navigation satellites plus HDOP and satellite Fix Status. It also provides the ability to select the SD satellite and to reset the GPS system.

- To select GPS Set Up:

1. Press the **PAGE** key to display the SET UP functions:

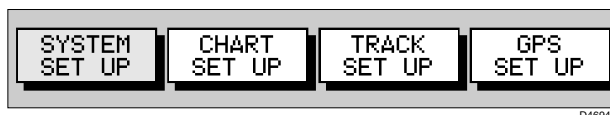

2. Use the trackpad to highlight the GPS SET UP function and press **ENTER** to display the GPS STATUS screen and soft key. GPS STATUS is displayed.

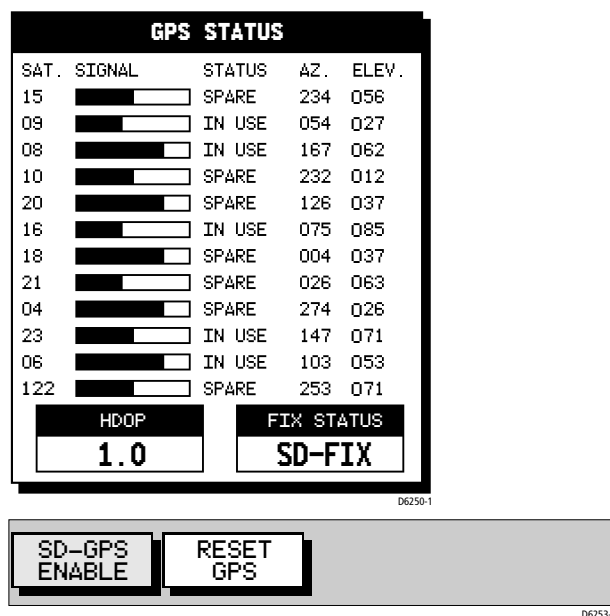

Figure 4-3: GPS Status Screen and Soft Key

The GPS STATUS screen provides, for each tracked satellite, the satellite number, a graphical signal strength bar, status, azimuth angle and its elevation angle from your vessel.

Positional accuracy is dependent upon these parameters; in particular, the azimuth and elevation angles are used in a triangulation process to calculate your position. HDOP (Horizontal Dilution Of Position) is a measure of this accuracy; a higher figure signifies greater error. In ideal circumstances, the figure should be in the region of 1.0. The Fix Status can indicate:

- SD-FIX, where a Satellite Differential fix has been acquired
- FIX OK, where a normal GPS fix has been acquired
- NO FIX, where no satellite fix can be acquired

➤ To enable or disable SD-GPS mode.

1. Using the trackpad left/right highlight SD-GPS in the function bar.



2. Press **ENTER** to toggle between SD-GPS ENABLE and SD-GPS OFF.
 - Select **ON** to allow the unit to use SD corrections if available.
 - Select **OFF** to force the unit to calculate a normal GPS fix with no satellite GPS corrections.
3. Press **CLEAR** twice to return to the normal display.

➤ To reset SD-GPS.

1. Using the trackpad left/right highlight RESET GPS in the function bar and press **ENTER**.
2. Press **CLEAR** twice to return to the normal display.

Chapter 5: Operation

5.1 Introduction

This chapter explains how to use the chart functions to navigate with the RC435/435i.

5.2 Working with Waypoints

The RC435 and RC435i Chartplotters enable you to place up to 500 waypoints. A waypoint is a position entered on a chart as a reference or destination point. All waypoints placed on the chartplotter are stored in a waypoint database list which includes symbol, position, bearing, range, date and time.

All waypoints in the database are displayed on screen, unless the **SHOW WAYPOINTS** is set to **OFF** in the Chart Set Up menu, as described on *page 41*. A waypoint can be selected, either on-screen or from the list, for editing.

Waypoints can be placed either using the cursor, or at the vessel's position, or at a specific lat./long. Waypoints can also be placed before the chartplotter is installed on your vessel.

When a new waypoint is placed, it is displayed using either the default symbol of a cross or an alternative symbol available from the Chart Set Up menu, as described in *Chapter 4*. The waypoint is added to the waypoint list and named with the next available number.

The edit functions can be used to change the symbol and name. When the cursor is positioned over a waypoint, the waypoint bearing and range are displayed.

Waypoints can also be transferred between the chartplotter, other NMEA connected instruments or a PC, using the Waypoint Transfer functions.

This section explains how to perform the following tasks using the on-screen cursor and the waypoint list:

- Placing a Waypoint
- Selecting a Waypoint
- Displaying Waypoint data
- Editing a Waypoint (symbol, name & position)
- Erasing a Waypoint
- Moving a Waypoint

Placing a Waypoint

Note: *It is not possible to place multiple waypoints at the same position.*

► To place a new waypoint:

1. From chart mode, press **ENTER**; the primary function bar is displayed

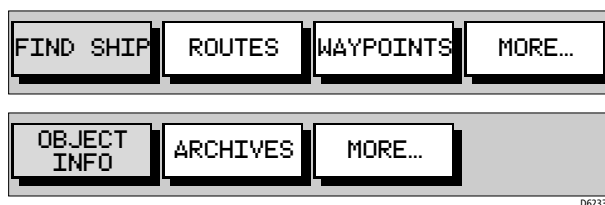

2. Using trackpad left/right, select **WAYPOINTS**.



3. To place a waypoint at the cursor position:
 - i. Select **PLACE WPT AT CURSOR**. A description of the options available is displayed.

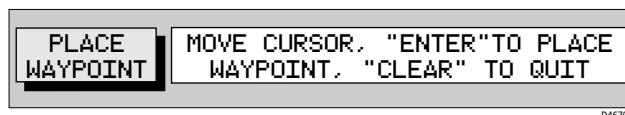

- ii. Place the cursor in the desired position on the chart and press **ENTER** to place the waypoint. The waypoint is added to the waypoint list and named using the next available number. The waypoint functions remain displayed so that further waypoints can be placed. Use **EDIT WAYPOINT** to name the waypoint as described in *Editing Waypoint Details* on page 52.
 - iii. When finished placing waypoints, press **CLEAR**.
4. To place a waypoint at the vessel's position:
 - Select **PLACE WPT AT VESSEL**. A new waypoint is placed at the vessel's current position. If there is no position data available then no waypoint is placed.

5. To place a waypoint at a known position (lat./long):
Select PLACE WPT AT POS. A box appears in the center of the screen with the current cursor position (lat./long). Use the trackpad left/right to select the value and the trackpad up/down to change the value. Press **ENTER** to place the waypoint or **CLEAR** to cancel.
6. To place a waypoint using the Waypoint List:
Select WAYPOINT LIST. The Waypoint List and associated function Soft Keys are displayed:

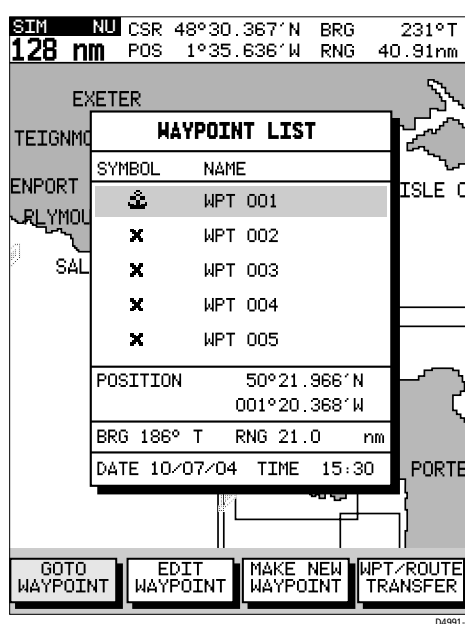

Figure 5-1: Waypoint List Display

7. Select MAKE NEW WAYPOINT.
The waypoint is placed at the current vessel position or, if a GPS fix is not available, the cursor position. The new waypoint is added to the Waypoint List and named with the next available number.
The EDIT WAYPOINT function is now highlighted allowing you to change the waypoint name, symbol or position. See *page 52* for detailed information.
To return to chart mode, press **CLEAR** twice.

Selecting a Waypoint

Positioning the cursor over a waypoint selects that waypoint and accesses the WAYPOINT OPTIONS function bar. This enables you to GoTo (described in *Section 5.4*), edit (name, symbol), erase or move the waypoint.

Selecting a waypoint from the Waypoint List allows you to GoTo and edit (symbol, name, position, erase) the waypoint. The Waypoint List also provides options to make a new waypoint and transfer waypoints.

► To select a waypoint using the cursor:

1. Move the cursor over the waypoint; the WAYPOINT OPTIONS function bar, together with help text, is displayed:

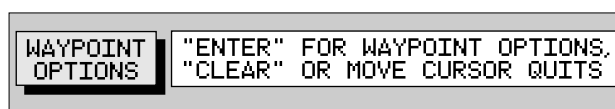

2. Press **ENTER** to select the waypoint function bar.

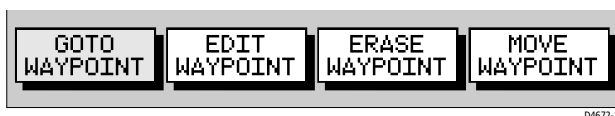

The selected waypoint can be edited via these functions.

► To select a waypoint using the Waypoint List:

1. Press **ENTER** to display the primary function bar.

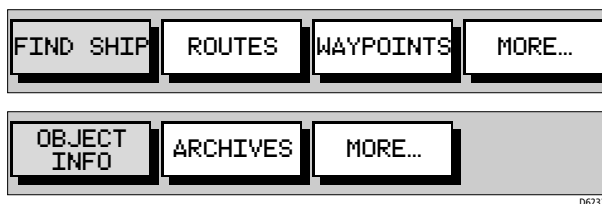

2. Select WAYPOINTS and press **ENTER** to display the waypoint function bar.



3. Select **WAYPOINT LIST** and press **ENTER** to display the Waypoint List. The Waypoint List and associated function bar are displayed (see *Figure 5-1*).
The list details all waypoints. The selected waypoint is indicated by the highlight bar with its position; bearing and range are provided (if GPS fix available).
4. Use trackpad up/down to move through the list to highlight the desired waypoint.

The selected waypoint can be edited using the **EDIT WAYPOINT** function.

Waypoint Data Display

Waypoint data can be viewed in two ways: the cursor can be used to select the waypoint to display the waypoint data in the status bar at the top of the screen, or the waypoint details can be viewed on the waypoint list.

- To display waypoint data:
Move the cursor over the waypoint. The waypoint data is displayed in the status bar, indicating waypoint number/name, bearing and range from vessel (dashes are shown if no fix is available).
While the cursor is over the waypoint, the **WAYPOINT OPTIONS** function bar is displayed.
- To remove the waypoint data:
Move the cursor away from the waypoint or press **CLEAR**.
- To display the waypoint details from the waypoint list:
Select the waypoint in the list as described above.
The details for the selected waypoint are displayed in the lower half of the window. Date and time are included for all waypoints where this information was available when the waypoint was placed.
To remove the Waypoint List and return to chart mode, press **CLEAR** three times.

Editing Waypoint Details

The name, symbol and position of a waypoint can be changed, either by means of the cursor or via the Waypoint List.

Note: *The target waypoint cannot be edited.*

► To edit a waypoint using the cursor:

1. Place the cursor over the waypoint.
2. Select WAYPOINT OPTIONS and press **ENTER** to display the Edit Waypoint function bar.
3. Select EDIT WAYPOINT. The Edit Waypoint function bar is displayed.



4. To edit the waypoint name, select EDIT NAME. The NAME WAYPOINT window is displayed.
5. Use the trackpad to enter or edit the name as follows:
 - Use trackpad left/right to move the cursor to the character to be changed. Up to eight characters can be used.
 - Use trackpad up/down to scroll through the characters.
 - When editing is complete, press **ENTER**; the waypoint name is updated and the window is removed.
6. To edit the symbol, select EDIT SYMBOL. The SELECT SYMBOL options are displayed.

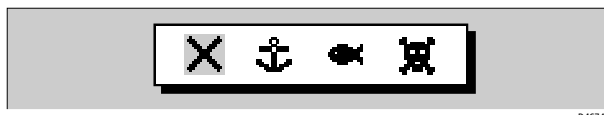

7. Use trackpad left/right to highlight the desired symbol, then press **ENTER**.

► To edit a waypoint using the Waypoint List:

1. From chart mode, press **ENTER** to display the primary function bar.

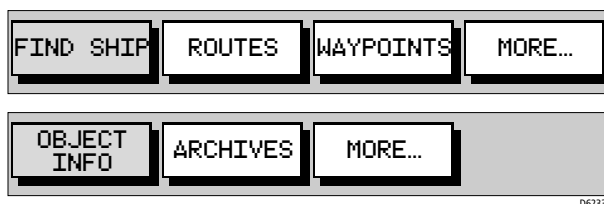

2. Using trackpad left/right, select WAYPOINTS.

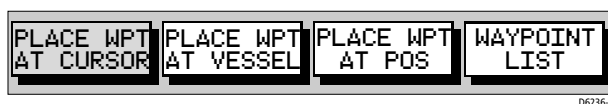

3. Select WAYPOINT LIST; the Waypoint List is displayed, with its associated function bar.

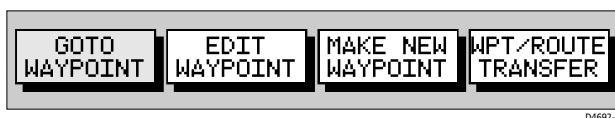

4. Select EDIT WAYPOINT; the waypoint edit functions are displayed.

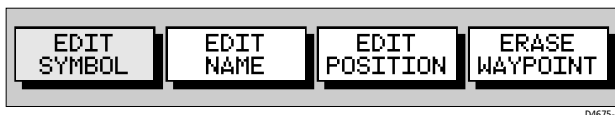

5. To edit the waypoint name, select EDIT NAME; the cursor is placed in the name field of the selected waypoint.
 - i. Edit the name as previously described (up to eight characters).
6. To edit the waypoint symbol, select EDIT SYMBOL.
 - i. Use trackpad left/right to highlight the desired symbol.
 - ii. Press **ENTER** to accept the choice or **CLEAR** to abort the operation.
7. To change the waypoint's position, select EDIT POSITION. The cursor is placed in the Position field in the Waypoint List.
 - i. Use trackpad left/right to select the latitude/longitude fields.
 - ii. Use trackpad up/down to scroll through and edit the values.
 - iii. When editing is complete, press **ENTER** to save the new position or **CLEAR** to abort the operation.

Erasing Waypoints

Note: A waypoint that is the target waypoint or waypoints that are also used in any saved route(s) cannot be erased. If an attempt is made to erase a waypoint that is used in a saved route, the warning “WAYPOINT IS USED IN ROUTE(S) AND CANNOT BE ERASED” is displayed.

- To delete a waypoint using the cursor:
 1. Place the cursor over the waypoint; see *Selecting a Waypoint* on page 50.
 2. Select WAYPOINT OPTIONS and press **ENTER** to display the Waypoint function bar.
 3. Select ERASE WAYPOINT. A warning box appears. Press **ENTER** to erase or **CLEAR** to retain. If erased, the waypoint list is updated and the screen is cleared.
- To delete a waypoint using the waypoint list:
 1. Select the waypoint from the waypoint list as previously described. The waypoint list function bar is displayed.
 2. Use trackpad up/down to move through the list to highlight the desired waypoint.
 3. Select EDIT WAYPOINT and press **ENTER** to display the Edit Waypoint function bar.
 4. Select ERASE WAYPOINT. Press **ENTER** to erase the waypoint. To return to chart mode, press **CLEAR** three times.

Moving Waypoints

Any waypoint, except the target waypoint, can be moved. The Waypoint function bar and cursor are used to move the selected waypoint, or the waypoint position can be edited.

Note: Take care when editing waypoints as it is possible to move waypoints that are used in routes stored in the Route Database List.

- To move a waypoint using the cursor:
 1. Place the cursor over the waypoint; see *Selecting a Waypoint* on page 50.
 2. Select WAYPOINT OPTIONS and press **ENTER** to display the Edit Waypoint function bar.
 3. Select MOVE WAYPOINT. The selected (highlighted) function now has help text appended to it.

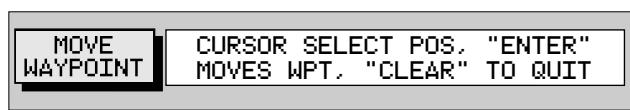

4. Move the cursor to the desired waypoint position.
5. When the cursor is in the correct position, press **ENTER** to set the new position and return to normal cursor control.

To return to chart mode, press **CLEAR** twice.

► To move a waypoint using the Waypoint List:

1. Select the waypoint using the Waypoint List as described above. The waypoint functions are displayed.
2. To edit the waypoint position proceed as previously described in *Editing Waypoint Details* on page 52.

5.3 Working with Routes

A route is made up of a series of waypoints (maximum 50). A route is made by placing a series of waypoints on the chart.

When a route is created it becomes the current route and is displayed on-screen. The current route is maintained after power-off. Only one route can be current and is displayed (if it is in the field-of-view) as solid lines connecting waypoints. If following the route, the current leg is shown as a dotted line.

After a route has been created, the **GOTO** key can be used to follow the route. The **GOTO** key provides various other options as described in *Section 5.4, Following Routes and Going to Target Points*.

Up to 20 routes can be saved in the route database. Any one of these can be selected from the database to be used as the current route.

The current route can be edited by adding and/or moving waypoints. When a route has been saved, options are also provided to name or erase a route.

This section explains how to perform the following tasks:

- Create a new route
- Save the current route in the database
- Clear the current route
- Retrieve a route from the database list as the current route
- Display route information, including route leg data and waypoint details

- Use the database list to erase and name existing routes
- Edit a route by adding, removing and moving waypoints

Note: The system is limited to 500 unique waypoints yet 20 routes of 50 waypoints as stated above are permissible. This figure is achieved by using waypoints in more than one route.

► To access the route function bar:

1. Press **ENTER** to display the primary function bar.

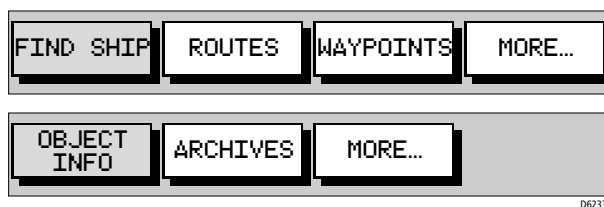

2. Select ROUTES to display the first level functions.

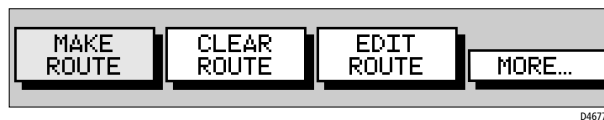

3. Select MORE to see more functions.

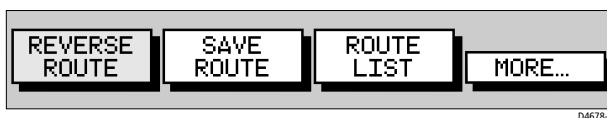

4. Select MORE again to return to the first level functions.
5. Press **CLEAR** twice to return to chart mode.

Creating a New Route

Note: If there is a current route on screen, it is cleared when MAKE ROUTE is selected. Ensure that this route is saved before continuing. If following the current route you must STOP FOLLOW (see page 72) before a new route can be created.

Waypoints in a route can be added/removed after it has been created, either via the ROUTES function or via the cursor (see Editing a Route in the following sections).

- To make a new route by placing waypoints:

Note: You can pan the chart and change the scale while placing waypoints.

1. If necessary, move the cursor to the desired area in which to make the route and select a suitable chart scale.
2. Select ROUTES then MAKE ROUTE. The MAKE ROUTE function is replaced with PLACE WAYPOINT, together with help text:

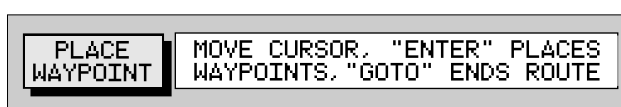

3. Move the cursor to the position on the chart where the first waypoint is to be placed and press **ENTER**.

Note: You can place the cursor on an existing waypoint, if desired; the PLACE WAYPOINT function changes to USE THIS WAYPOINT. Press **ENTER** to use the waypoint.

The waypoint appears on the screen at the cursor position. The number displayed alongside the waypoint identifies its position in the route.

Note: If the route is Cleared before it is saved, the waypoint is removed.

4. Move the cursor to the next waypoint position; a dotted line connects the cursor to the last placed waypoint.
5. Press **ENTER** again. The next waypoint is placed and the dotted line changes to a solid line.

Note: If the waypoint was placed incorrectly, it can be deleted by pressing **CLEAR**. Successive waypoints can be deleted in this way.

6. Repeat Step 4. and Step 5. until all waypoints have been placed. Up to 50 waypoints can be included in a route. Any existing waypoint(s) can be included by placing the cursor on the waypoint(s).
7. When all your waypoints have been entered, press the **GOTO** key to complete the route. The route is displayed on screen and is the current route but is not active, that is, not being followed.
8. Select MORE to access the SAVE ROUTE function, or **CLEAR** to return to chart mode.

Note: The completed route is stored in the unit's memory and will be re-displayed if the unit is switched off and on again. However, Raymarine recommends that you save the route as described below. The current route waypoints do not appear in the waypoint list until the route is saved.

Saving the Current Route

You can save up to 20 named routes in the route database. These routes can then be re-displayed and followed subsequently.

Note: *If you attempt an operation that affects this route (CLEAR ROUTE, for example) before the current route is saved, you are prompted to save it.*

► To save and name the current route:

1. Select ROUTES, followed by MORE.
2. Select SAVE ROUTE. The Save Route list is displayed.
3. The next available entry on the list is highlighted. You can use trackpad up/down to select another position in the list, which can be a blank slot or an existing route you no longer need.

SAVE ROUTE	
1	ROUTE 01
2	-
3	-
4	-
5	-

D4680-1

4. Press **ENTER** to save the route.
Press **ENTER** again (in response to the prompt) to name the route or **CLEAR** to save as the default ROUTE XX, where XX is the next available number.

When naming a route, use the trackpad to move the cursor right or left to the character to be edited. Use trackpad up/down to scroll through the characters. The name can contain up to eight alphanumeric characters, including spaces.

5. Press **ENTER** to finish and clear the Route List, then press **CLEAR** twice to return to the chart mode.

Clearing the Current Route from the Screen

To clear the current route from the screen, select CLEAR ROUTE. If the current route has not been saved, you are prompted to save it.

- To clear the current route from the screen:
 1. Select ROUTES or place the cursor over a route leg until the leg data is displayed in the Status Bar.
 2. Select CLEAR ROUTE and press **ENTER** to clear the route or press **CLEAR** to cancel the operation.
 3. If the route has not been saved, a prompt gives the options **ENTER** to save or **CLEAR** to remove the route from the screen.
 4. To save the route in the database, press **ENTER**. The Name Route functions are displayed, see *Saving the Current Route* on page 58.

Retrieving a Route from the Database

A route from the database list can be selected as the current route. The list is accessed from the second set of ROUTES functions.

- To select a route as the current route:
 1. Select ROUTES, followed by MORE, then ROUTE LIST. The route list is displayed with the currently selected route highlighted (*Figure 5-2*).
 2. Select SHOW ROUTE. The route list is removed and the selected route is shown on screen as the current route.

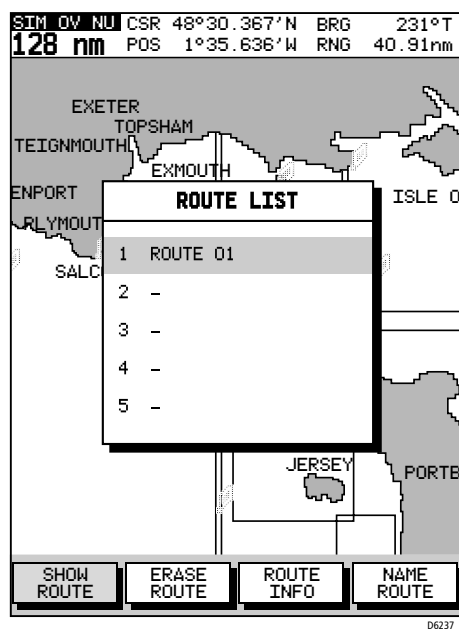

Figure 5-2: Route List Display

Displaying Route Leg and Waypoint Information

- To display information about a route leg, move the cursor over the leg until its data is displayed in the status bar at the top of the screen

```
ROUTE : - LEG: FROM WPT 004 BRG 180° T
CURRENT TO WPT 005 RNG 28 nm
```

D4682_1

To remove the data, move the cursor away from the route leg or press **CLEAR**.

- To display information about a route waypoint, move the cursor over the waypoint until its pop-up data box is displayed.

```
WAYPOINT : - 220° T 295 nm
WPT 004
```

D4683_1

To remove the data, move the cursor away from the waypoint or press **CLEAR**.

Erasing or (re)Naming a Route

A route can be deleted or re-named via the Route List. When deleting a route, you are prompted to confirm.

- To select a route to delete:
 1. Select **ROUTES**, followed by **MORE**, then **ROUTE LIST**. The route list is displayed with the selected route highlighted.
 2. Select **ERASE ROUTE**.
 3. Press **ENTER** to erase the route from the list. A warning box appears, prompting you to press **ENTER** to confirm or **CLEAR** to cancel the operation.
 4. Press **CLEAR** three times to return to normal chart operation.
- To select a route to (re)name:
 1. Select **ROUTES**, followed by **MORE**, then **ROUTE LIST**. The route list is displayed with the selected route highlighted.
 2. Select **NAME ROUTE**. and press **ENTER**.
 3. To name or rename a route, use trackpad left/right to select each character to be edited. Use trackpad up/down to scroll through the characters.
 4. Press **ENTER** to accept the new name or **CLEAR** to cancel the operation.
 5. Press **CLEAR** three times to clear the Route List and return to chart mode.

Route Info

A list of the waypoints in your route, their bearing and range, the time taken to complete and estimated time of arrival (ETA) can be obtained by using the **ROUTE INFO** function.

1. Select **ROUTES**, followed by **MORE**, then **ROUTE LIST**. The route list is displayed with the selected route highlighted.
2. Select **ROUTE INFO**. and press **ENTER**.

SLIP	NU	CSR	25°43.955'N	RNG	0.04 nm			
16	nm	POS	80°09.013'W	BRG	180°M			
INFO FOR ROUTE - ROUTE001								
WPT	POSITION	BRG	RNG	TOTAL	TIME			
		°M	nm	nm	HOURS			
01	25°43.487'N 080°11.426'W	---	0.0	0.0	00:00			
02	25°44.236'N 080°07.738'W	257	3.42	3.42	00:41 + 0 DAYS			
03	25°38.082'N 080°07.186'W	355	6.17	9.60	01:55 + 0 DAYS			
04	25°38.082'N 080°13.357'W	90	5.56	15	03:01 + 0 DAYS			
AT SOG <USER SELECTED> 5.0 Kts								
DATE 10/07/04 TIME 00:00								
<table border="1"> <tr> <td>TIME ETA</td> <td>ACTUAL SOG</td> <td>PLANNED SOG</td> </tr> </table>						TIME ETA	ACTUAL SOG	PLANNED SOG
TIME ETA	ACTUAL SOG	PLANNED SOG						

06238-2

Figure 5-3: Route Info

The route is displayed as a series of legs. For each leg the next waypoint position, leg bearing, leg distance, total distance and elapsed time at current Speed over Ground (SOG) is listed. Press the trackpad up/down keys to scroll through the list.

- To display the ETA at each route waypoint select **TIME ETA** and press **ENTER**.
- To enter a planned SOG (rather than actual SOG) select **PLANNED SOG** and press **ENTER**.
Use the trackpad left/right keys to change the planned SOG value and press **ENTER** to recalculate route with this value.
- To recalculate using actual SOG, select **ACTUAL SOG** and press **ENTER**.
- Press **CLEAR** four times to return to chart mode.

Editing a Route

A route may be edited in order to:

- Add a Waypoint into a route
- Remove a Waypoint from a route
- Move a Waypoint (as described in *Section 5.2*)
- Reverse a Route

Any changes made to the route affect only the current route, so the route must be saved in order to keep the changes.

Inserting/Deleting Waypoints in a Route

- To add waypoint(s) to the end of a route:

Note: *If no current route is displayed, select a route from the Route List and use the SHOW ROUTE function to make it active, see Retrieving a route from the database.*

1. Select ROUTES then EDIT ROUTE and press **ENTER**; the PLACE WAYPOINT function is displayed.
2. Add waypoint(s) to the route by moving the cursor and pressing **ENTER** in the same way as the route was first created.
3. Remove waypoints from a route by pressing **CLEAR** in the same way as the route was first created.
4. When your changes are complete, press the **GOTO** key to end route editing.
5. Press **CLEAR** twice to return to chart mode.

Note: *When deleting waypoints, if the route has not been saved, the waypoint is erased. If the route has been saved, the waypoint remains on the screen.*

- To insert a waypoint into a route:

1. Move the cursor over the route leg where a waypoint is to be inserted. The route leg data is shown in the status bar and the ROUTE OPTIONS function, with help text, is displayed:

```
ROUTE : - LEG: FROM WPT 004   BRG 180° T
CURRENT   TO WPT 005   RNG 28   nm
```

D4682_1

```
ROUTE  "ENTER" FOR ROUTE OPTIONS.
OPTIONS "CLEAR" OR MOVE CURSOR QUIT
```

D4720_1

2. Press **ENTER**; the Route Leg functions are displayed:

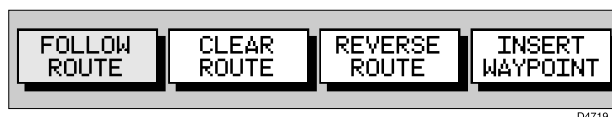

3. Select **INSERT WAYPOINT**.
The cursor now controls the route leg which is connected to the existing waypoints on either side of the cursor by a dotted line.
4. Using the trackpad, move the cursor to the desired position and press **ENTER** to place the new waypoint and return to normal cursor operation or **CLEAR** to cancel the operation.

Note: *If you move the cursor over an existing waypoint, the option to use this waypoint appears.*

5. Press **CLEAR** again to remove the function bar and route leg data.
The waypoints in the current route are re-numbered to identify the new positions.

Note: *If you already have 50 waypoints in your route the system will not allow you to add any more and a warning message will be displayed.*

- To remove a waypoint from the route using the cursor:

1. Place the cursor over the waypoint.
2. Select **WAYPOINT OPTIONS**; the Waypoint functions are displayed.
3. Select **REMOVE WAYPOINT**; the waypoint is removed from the route and the remaining waypoints in the current route are renumbered accordingly.

Note: *The waypoint is erased if the route is not saved but remains on screen if the route is saved.*

5.4 Following Routes and Going to Target Points

The **GOTO** key accesses the functions to follow a route or go to a waypoint, port, nearest facility or current cursor position. When the target destination is selected, the chartplotter calculates bearing, distance and cross track error; this information can be repeated on other instrumentation and passed to an autopilot via NMEA. Cross Track Error (XTE) can be reset to zero from the actual vessel position.

When the chartplotter is following a route, the target destination is indicated by a square around the waypoint (or cursor marker) and a dotted line shows the intended track, from the start point or previous waypoint, to the target waypoint.

This section explains how to perform the following tasks:

- Follow a route
- Reverse a route
- Target Point Arrival
- Altering the route, including joining at a selected waypoint, advancing waypoints and restarting XTE
- Go to an individual point, either an existing waypoint or the cursor
- Go to the nearest facility or a selected port
- Stop and Restart Follow/Goto

An alarm is triggered when approaching a waypoint. *Chapter 4* describes how to set the alarm.

► To access the follow and GoTo functions:

1. Press **GOTO** to display the first level GoTo functions:

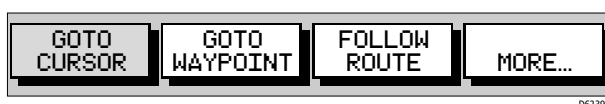

2. Select MORE to display the second level GoTo functions



3. Select MORE to return to the first level functions.
4. Press **CLEAR** to return to the chart screen.

Note: *The functions differ if a FOLLOW or GOTO is already in progress (see Stop Follow or Stop GoTo on page 72).*

Follow a Route

Note: *If a route has been reversed or if a route on screen was being followed, but stopped before completion, the target waypoint (outlined by a square box) may be different to when the route was created. The target waypoint should always be checked before initiating a FOLLOW ROUTE.*

► To follow the current route:

1. Press the **GOTO** key. The GoTo/Follow functions are displayed. Alternatively, place the cursor over a route leg until the Route functions are displayed.
2. Select FOLLOW ROUTE.

The vessel's current position becomes the origin and the first waypoint in the current route becomes the target waypoint. A dotted line connects the vessel's current position to the target waypoint. This line remains fixed on screen as the vessel moves. The function bar is removed.

Reverse a Route

This option enables a return route to be generated from an existing route which is then followed in reverse order, with waypoints renumbered accordingly.

► To reverse the current route:

From the normal chart display:

1. Press **ENTER** to display the primary function bar, then select ROUTES, followed by MORE, then REVERSE ROUTE.

—or—

2. Move the cursor over a route leg until the ROUTE OPTIONS function is displayed. Press **ENTER** to display the options and select REVERSE ROUTE.

The current route is reversed on the screen and the waypoints are renumbered.

► To follow the reversed route:

1. Press the **GOTO** key. The GoTo/Follow functions are displayed.
2. Press FOLLOW ROUTE.

The vessel's current position becomes the origin and the first waypoint in the reversed route becomes the target waypoint. The function bar is removed.

Target Point Arrival

Target alarms (see *Chapter 5*) can be set up to sound when the vessel is approaching the target point. The arrival alarm is defined as a circle (not visible on the screen), with a specified radius around the target.

The alarm is triggered when either of the following conditions is met:

- The distance to the target point is less than that specified for the Arrival alarm.
- The vessel reaches the closest point of approach to the target (it crosses a line passing through the waypoint and perpendicular to the track).

- Once the alarm is triggered, the vessel goes towards the next waypoint in the route. Press any key to cancel the arrival alarm.

The target becomes the origin, the next waypoint becomes the target point and the two are connected by a dotted line indicating the current leg.

If the target waypoint was the subject of a GoTo, or was the last waypoint in a route, the pop-up alarm is cleared.

Alter a Route

A route can be followed from a selected waypoint (Join a route) or, if already following, advanced to the next waypoint. Also the XTE can be restarted, setting the current vessel position as the new origin.

In addition, a selected waypoint can be moved as described in *Section 5.2*, or removed from the route as described in *Section 5.3*.

Join a Route

- To start following the current route from a selected waypoint:
 1. Move the cursor over a route waypoint until the WAYPOINT OPTIONS function is displayed.

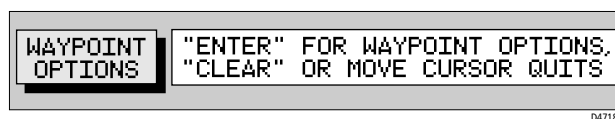

D4718-1

2. Press **ENTER** and select FOLLOW FROM HERE.

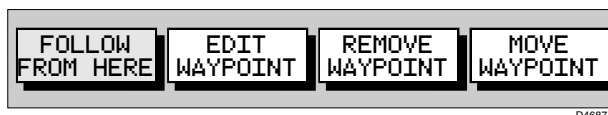

D4687_1

The vessel follows the route, using the selected waypoint as the target.

Advance to a Waypoint

When following a route it is possible to advance to the next waypoint, even if the current target waypoint has not been reached.

➤ To advance to a waypoint:

1. Press the **GOTO** key to display the GoTo/Follow functions:



D4688_1

2. Select WAYPOINT ADVANCE. The current leg of the route is abandoned and the next waypoint becomes the target. The display is updated to show the new route leg.

Restart Cross Track Error (XTE)

Restart XTE is useful if you find yourself off track and prefer to go directly to your target, rather than get back onto the original track.

While following a route, or going to a target point, you can restart the XTE. This sets the XTE to zero and moves the origin to the vessel's actual position.

CAUTION:

Care must be taken when restarting XTE that your new track does not take the vessel into a dangerous situation.

➤ To restart XTE:

1. Press the **GOTO** key.

If following a route, the following functions are displayed.



D4688_1

If a GoTo is in progress, the following functions are displayed:



2. Select RESTART XTE. The dotted line between the original origin and the target waypoint is redrawn from the vessel's current position to the target waypoint and the XTE is reset to zero

Going to an Individual Target

Rather than following a route, you can go directly to a selected target. This can be an existing waypoint, a port or nearest facility or the current cursor position.

Go to a Waypoint

To navigate directly to an existing waypoint:

1. From the normal chart display:
 - i. Use the trackpad to position the cursor over the desired waypoint until the waypoint options function is displayed:

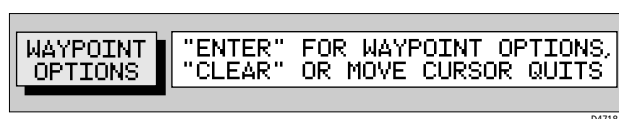

...then press **ENTER** to display the waypoint functions:

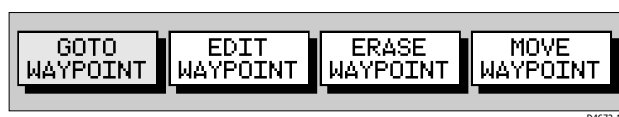

—or—

- ii. Press the **GOTO** key to display the waypoint options and select GOTO WAYPOINT; the waypoint list appears. Use the cursor to select the desired waypoint:

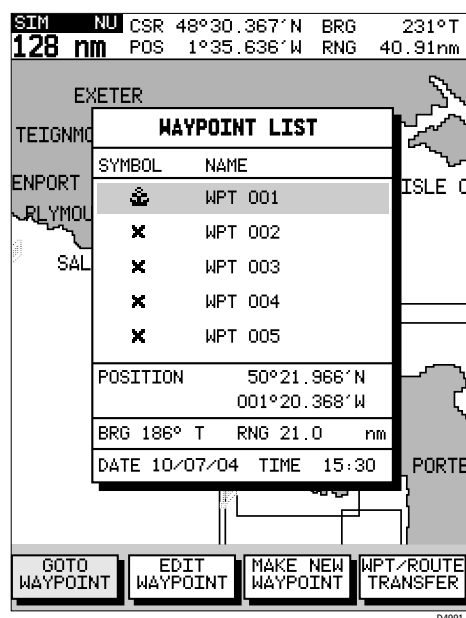

Figure 5-4: Waypoint List

A waypoint also can be selected from the Waypoint List as described in *Working with Waypoints* on page 47.

2. Select **GOTO WAYPOINT**.

A dotted line is drawn from the vessel's current position to the selected waypoint and navigation to the selected waypoint begins.

Go to Cursor

Note: *If navigation is currently in progress or if the cursor is homed (Find Ship) it is not possible to go to cursor.*

► To navigate directly to the current cursor position:

1. Press the **GOTO** key and select **GOTO CURSOR**. The **GOTO CURSOR** function now has help text appended to it:

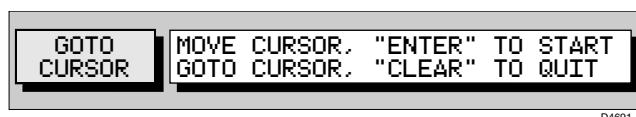

2. Use the trackpad to position the cursor as desired.
3. Press **ENTER** to start the GOTO, or **CLEAR** to cancel the operation.

A temporary waypoint is placed at the cursor position and navigation proceeds towards it. The temporary waypoint is shown as a square with a dot in the center and is connected to the vessel's starting position by a dotted line.

On arrival, the arrival alarm is sounded and the arrival pop-up box is displayed. The dotted line is removed but the temporary waypoint remains on screen until another GOTO or FOLLOW operation is started, or the waypoint is removed.

Note: *The temporary waypoint is not added to the waypoint list. If the GoTo is stopped prior to completion or the temporary waypoint is erased.*

Go to a Port

You can navigate directly to the nearest port or to a selected port or facility.

► To navigate directly to selected port:

1. Press the **GOTO** key, select MORE, and then GOTO PORT to display the Port List.
2. Use trackpad up/down to select the desired port and press **ENTER** to start the GoTo, or **CLEAR** to cancel the operation.

A dotted line is drawn between the current vessel position and the target waypoint which is placed at the port. The line remains fixed on the screen as the vessel moves.

Bearing, Range and Cross Track Error are calculated for the target waypoint in the same manner as for any other GoTo or Follow function.

On arrival, the arrival alarm is sounded and the arrival pop-up box is displayed.

► To navigate directly to the nearest port or facility:

1. Press the **GOTO** key and select MORE and then GOTO NEAREST to display the list.

The list shows the eight nearest places where the selected facility exists, in order of distance. The bearing and range (in selected units) for each one is shown.

2. Use trackpad up/down to select the desired destination and press **ENTER** to start the GoTo, or **CLEAR** to cancel the operation.

The operation is conducted in the same manner as for GOTO PORT above.

Stop Follow or Stop GoTo

- To stop following the route or target point:
 1. Either press the **GOTO** key or move the cursor over the target waypoint.
 2. Select the STOP GOTO or STOP FOLLOW function:

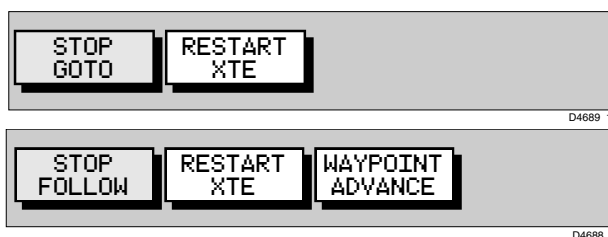

The dotted line from the vessel to the target waypoint disappears.

5.5 Changing the Display Mode

Use the **PAGE** key to select the desired display mode. Repeat presses of the **PAGE** key provide the following display modes:

- Set Up functions (see *Chapter 4*)
- Course Deviation Indicator (CDI)
- Bearing & Distance Indication (BDI)
- Waypoint data
- Navigation data
- Time/Date data
- Return to Chart display

Note: Press the **GOTO** key in any display mode to return to normal Chart display.

- To change the display mode:
 1. Press the **PAGE** key to show the SET UP functions with SYSTEM SET UP highlighted:

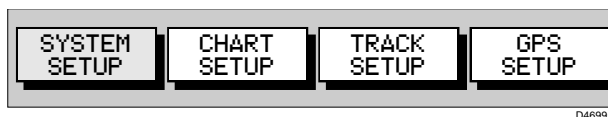

2. Repeat Step 1 to cycle through each of the available display modes.

Note: The Set Up Function Bar remains displayed in each display mode. To remove the Set Up Function Bar, press **CLEAR**.

CDI Display

The CDI display shows Cross Track Error (XTE) and distance to waypoint presented in a “runway” format:

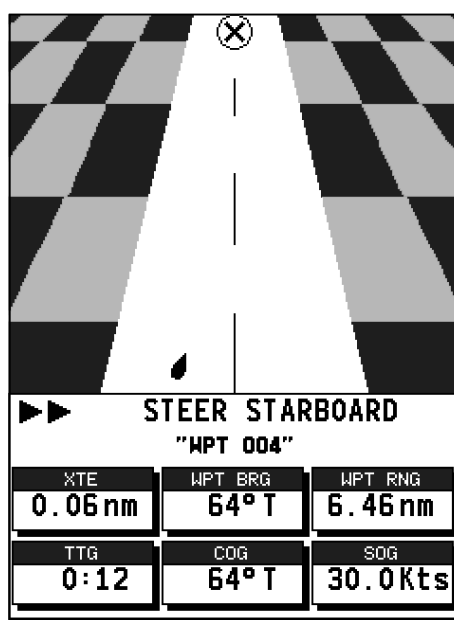

Figure 5-5: CDI Display

The runway represents a 0.3nm width with the vessel symbol shown on the center line when the vessel is on course. Cross Track Error (XTE), Bearing to Waypoint, Distance to Waypoint, Time to Go (TTG), Course Over Ground (COG) and Speed Over Ground (SOG) are also shown. Time to Go is calculated on the basis of distance to destination and Speed Over Ground (SOG) towards the destination.

At waypoint ranges greater than 4nm, the symbol remains at the top of the screen. As the waypoint range falls below 4nm, the symbol moves down the center line.

The checkered pattern moves down the screen to simulate movement when SOG is greater than 2 knots.

The steering instruction is **STEER STARBOARD** if the XTE is 0.01nm or more to port, **STEER PORT** if the XTE is 0.01nm or more to starboard or **ON COURSE** if the XTE is less than 0.01 on either side. If no GoTo or Follow is in progress, the steering instruction is **NOT TRACKING**.

The graphical XTE indication places arrows either side of the steering instruction and pointing towards it, dependent on the value of XTE.

The first arrow is shown when the XTE reaches 0.01nm, the second at 0.05nm and subsequently at 0.1nm intervals.

BDI Display

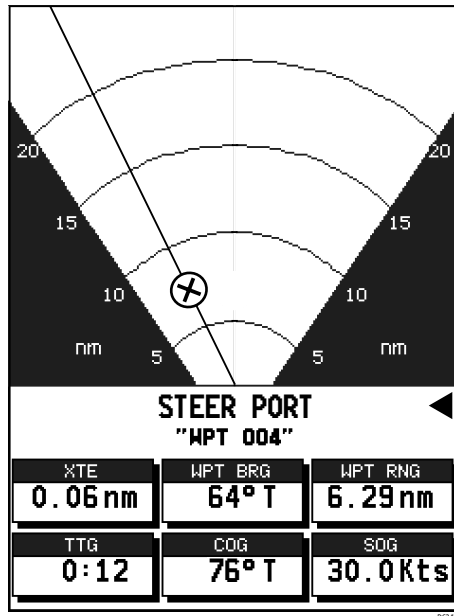

Figure 5-6: BDI Display

The BDI display shows deviation from the bearing to waypoint and distance to waypoint. Cross track Error, Bearing to Waypoint, Distance to Waypoint, Time to Go, COG and SOG are also shown. Time To Go is calculated on the basis of distance to destination and velocity made good towards destination.

The line to the waypoint symbol is shown at an angle equal to the difference between the COG and the Bearing to Waypoint.

The range scale automatically scales for distance. The ranges shown are 1nm, 4nm, 20nm, 40nm, 100nm, 200nm, 400nm, 1000nm, 2000nm, 4000nm. In each case the range scale has graduations at $\frac{1}{4}$, $\frac{1}{2}$ and $\frac{3}{4}$ of the current scale.

The steering instruction for the BDI display uses the deviation from vessel bearing to waypoint bearing to instruct you to turn the vessel towards the target waypoint. This is different from the steering instructions in all other display modes, which use the XTE to assist you in steering the vessel back towards the rhumbline between origin and destination.

The steering instruction is STEER PORT if the waypoint line is 1° or more to port, STEER STARBOARD if the waypoint line is 1° or more to starboard or ON COURSE if the waypoint line is dead ahead. If no GoTo or Follow is in progress, the steering instruction is NOT TRACKING, no steering arrows are shown, but the rhumb line indicator is shown.

The graphical steering indication will place arrows either side of the steering instruction and pointing towards it dependent on the difference between COG and bearing to Waypoint. The first arrow is shown when the difference reaches 5° and thereafter at 5° intervals.

Waypoint Data

The Waypoint Data display comprises text data occupying the whole screen.

ROUTE	
"CURRENT"	
WAYPOINT 01	
"HILLHEAD"	
BRG	313° T
RNG	3.76 NM
COG 313°T	TIME 02:15 10/07/04
SOG 5.0 Kts	TTG 00:47
XTE 0.02nm	ETA 03:02 10/07/04
STEER STARBOARD	
>	

Figure 5-7: Waypoint Data

If a route is not selected, the ROUTE field displays NO ROUTE.

The WAYPOINT field shows the name of the waypoint. If the waypoint is part of a route then the title field includes the waypoint index in the route. If there is no target waypoint the text indicates NO WAYPOINT and all waypoint data is shown as dashes, one per character. If a route is being followed and the waypoint is not named, the text shows the waypoint number within the route (as displayed on screen). If a GOTO Cursor or Port is in progress, the text indicates GOTO CURSOR or GOTO <Port Name>.

BRG, RNG and XTE data relate to the target waypoint.

Time refers to time data which is acquired from GPS information. Any local time offset is set in the System Set Up menu, see *Chapter 4*.

The Time To Go (TTG) and Estimated Time of Arrival (ETA) data relate to the target waypoint (not the whole route) and are based on the Speed Over Ground (SOG) towards the target. If the VMG is negative, or data is not available, these fields are replaced by dashes, one per character.

The steering instruction is STEER STARBOARD if the XTE is 0.01nm or more to port, STEER PORT if the XTE is 0.01nm or more to starboard or ON COURSE if XTE is less than 0.01 on either side.

If no GoTo or Follow is in progress, the steering instruction is NOT TRACKING, no steering arrows are shown, but the rhumb line indicator is shown.

The graphical XTE indication places arrows either side of the rhumb line indicator and pointing towards it, dependent on the value of XTE. The first arrow is shown when the XTE reaches 0.01nm, the second at 0.05nm and subsequently at 0.1nm intervals.

Note: *The steering instruction and graphical XTE indication are repeated on all text-only displays.*

Navigation Data

The Navigation Data display comprises text data occupying the whole screen:

Textual data provides Position, SOG, COG, Bearing and Range to waypoint, Time, Fix status and the XTE indicator. Any unavailable data is replaced by dashes, one per character. When there is no GPS fix but there is a value for the last fix, this is shown instead; POSITION is replaced with LAST POSITION.

The (c) indicator only appears when the position has been user calibrated.

The Fix indicator shows the GPS Fix status and indicates either FIX OK, SD FIX or NO FIX.

POSITION 50°46.338'N 1°10.391'W
COG 313° T SOG 5.0 Kts
WAYPOINT "HILLHEAD"
BRG 313°T GPS FIX OK RNG 3.74nm TIME 02:15 10/07/04
STEER STARBOARD >

062442

Figure 5-8: Navigation Data

Note: Graphical XTE indicator is as per Waypoint Data on page 75.

Time/Date Data

The Time/Date display comprises text data occupying the whole screen:

Textual data provides Sunrise and Sunset time, Current Time/ Date, Waypoint and Route arrival times plus the XTE indicator.

Sunrise and Sunset times are for the selected day and at the selected position. The TODAY indicator emphasizes that the sunrise and sunset times relate to the current day. If another day is selected, the TODAY text is replaced with ON XX/XX/XX where XX/XX/XX is the selected date in the current format.

When the Time/Date screen is first opened, the data relates to the current day, unless there is no date information available. In this case dashes are displayed. The vessel's current position is used unless there is no GPS fix in which case the cursor position is used and shown as a USER SELECTED position.

The position data can be either as selected by you, in which case the text relating to the position is USER SELECTED, or the current position in which case the text is VESSEL.

SUNRISE	05:05	
SUNSET	21:14	TODAY
AT POSITION (VESSEL)		
	50°46.349' N	
	001°10.411' W	
TIME	02:18	
DATE	10/07/04	
ETA (WAYPOINT)	03:03	10/07/04
TTG (WAYPOINT)	00:44	
ETA (ROUTE)	03:44	10/07/04
TTG (ROUTE)	01:25	
STEER STARBOARD		
>		

Figure 5-9: Time/Date Data

The (c) indicator only appears when the position has been user calibrated.

The Time and Date fields show the local current time and date.

The TTG and ETA (WAYPOINT) data relates to the target waypoint. The TTG and ETA (ROUTE) data relates to the end of the route.

All data is based on the SOG towards the current target. If the SOG is negative, or data is not available, these fields are replaced with dashes, one per character.

► To display Sunrise/Sunset information for a different date:

1. If the Set Up functions are displayed, press **CLEAR** to remove them; press **ENTER** to display the position functions.

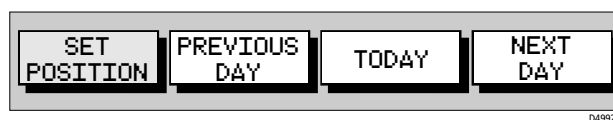

D4992-1

2. Select PREVIOUS DAY or NEXT DAY as desired to display Sunrise/Sunset information for a particular date.
3. Select TODAY to return the display to current date.

► To set the position data manually:

1. Display the Position functions as described for Sunrise/Sunset display above.
2. Select SET POSITION.
3. Select VESSEL POSITION, which sets the position to the current position of the vessel.

—or—

Select SELECT POSITION, which enables specific Latitude/Longitude data to be entered.

Use cursor left/right to select individual characters to edit.

Use cursor up/down to select the desired character.

4. Press **ENTER** to complete, or **CLEAR** to abort, the change(s).

5.6 Transferring Waypoints and Routes

There are two methods of transferring waypoints and routes. The first is via the NMEA interface and the second is via the Gold Chart card. The transferring to and from the Gold Chart card is described in the *Using Archives* section on page 86.

Displayed Waypoints

Waypoints and routes can be received and transmitted via NMEA. The NMEA link could be to a PC, typically via a spare RS232 COM port.

Managing Database Lists

The SEND WAYPOINTS function sends all waypoints in the Waypoint List and all routes in the Route List. Sending the Waypoint List does not affect current routes.

Note: *Sending the Waypoint List includes waypoints in an unsaved route.*

The RECEIVE WAYPOINTS function adds waypoints and routes received via NMEA to the Waypoint List and Route List.

Note: *Where multiple waypoints have the same position, the last waypoint sent is the only one included in the Waypoint List.*

► To send waypoints (and route lists):

1. In chart mode, press **ENTER**; the primary function bar is displayed:



2. Using trackpad left/right, select WAYPOINTS.



3. Select WAYPOINT LIST.

The Waypoint List is displayed, with its associated function bar:

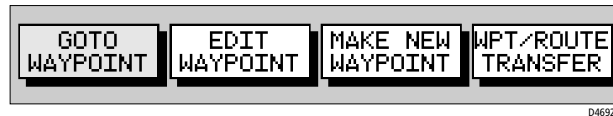

4. Initiate receiving of waypoints on the NMEA compatible equipment.
5. Select WPT/ROUTE TRANSFER.

The waypoint transfer functions are displayed:



6. Select SEND WAYPOINTS and press **ENTER**; the text changes to STOP SENDING.
7. To stop waypoint transfer, press **ENTER**.

➤ To receive waypoints and route lists:

1. Display the Waypoint List as previously described, then select WPT/ROUTE TRANSFER.
2. Select RECEIVE WAYPOINTS and press **ENTER**; the text changes to STOP RECEIVING and remains selected.
3. Initiate sending waypoints on the NMEA compatible equipment.
4. To stop waypoint transfer, press **ENTER**.

Note: *If either the Waypoint List or Route List becomes full, a warning is displayed and the operation is terminated.*

5.7 Using Tracks

The TRACK function is used to mark an on-screen trail that the vessel has followed, as if it had left a visible fixed wake.

While the track is turned on, it is recorded in the display unit's memory. You specify the interval at which track points are made and a line is drawn on-screen between each point. Up to 1000 track points can be saved.

The track remains on-screen, even following a Power off/on, until the track is cleared.

Using the *SmartRoute* function, a track can also be converted to and saved as a route which is automatically reversed, ready for use as a return voyage.

This section describes how to:

- Set up a track and specify the interval between track points
- Clear the current track
- Convert the track to a route (*SmartRoute*)

► To access the track controls:

1. Press the **PAGE** key to display the chart set up function bar:

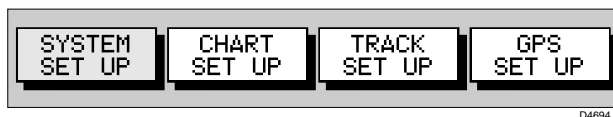

2. Select TRACK SET UP to display the Track function bar:



The following instructions assume that the track functions are displayed.

Setting up a Track

Use the track functions to switch the track on and to specify the interval at which track points are placed. The time interval between track points can be set to 1s, 10s, 30s, 1min, 10min or 30min. The distance spacing between track points can be set to 0.05nm, 0.1nm, 0.5nm or 1nm. The maximum track length is 1000 points. When this limit has been reached, track points continue to be placed, but the oldest points start to be deleted.

Track points continue to be placed until the track is switched off. The current track is retained even when the unit is powered off.

Setting a short time interval between track points is best suited to navigation within a close or complex environment such as an estuary or marina, whereas a greater distance interval is best suited to a long voyage.

When complete, a track can be converted to and saved as a route (*SmartRoute*).

Refer to the track interval setting guide below to determine the best setting for your planned voyage; this is particularly important if you wish to use *SmartRoute* to convert the track to a route.

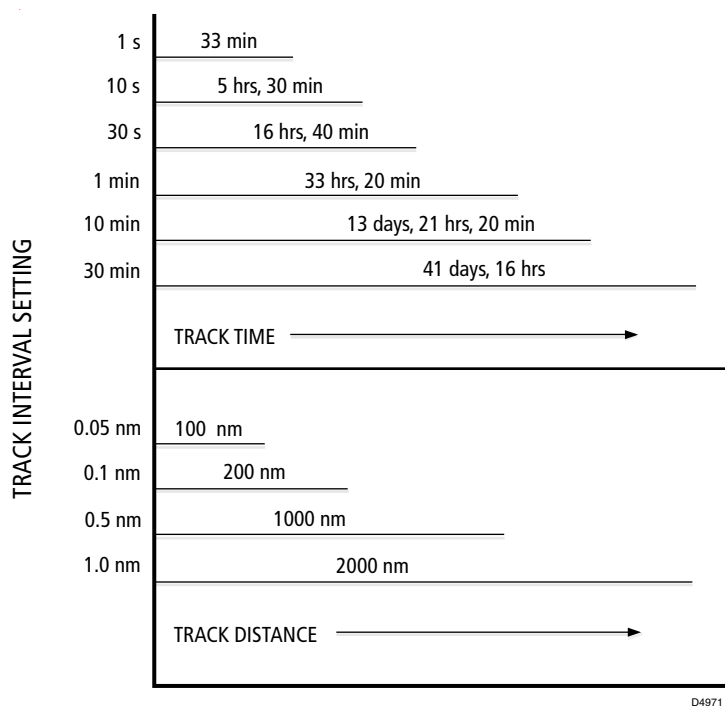

Figure 5-10: Track Interval Setting Guide

► To set up a track:

1. Select the INTERVAL function.
Use trackpad up/down to select the appropriate options to set either a time interval or a distance interval; press up to increase the interval or down to decrease the interval.

2. Use trackpad left/right to select TRACK ENABLE and press **ENTER**.
The TRACK ENABLE text changes to indicate TRACK OFF.

The vessel's track is displayed on-screen with a line joining the points at the selected interval.

Clearing the Current Track

The current track can be cleared from the screen.

- To clear the current track:

1. Select CLEAR TRACK.
The current track is cleared from the screen and memory.
2. If no further track points are to be placed, select TRACK OFF and press **ENTER**; the TRACK OFF text changes to indicate TRACK ENABLE.

SmartRoute

SmartRoute enables the latest track to be converted to a route.

- To convert a track to a route:

1. Select MAKE INTO ROUTE and press **ENTER**.
The current track is converted to a new route, with the most recently placed track point as the start of the route. In other words, the track is reversed.
If there is an unsaved current route on screen, the option to save the route is given, see *Section 5.3, Working with Routes*.
2. Check the calculated route and that the route deviation from the original, given in the warning box, is within navigable limits.

5.8 Object Information

The OBJECT INFO function provides detailed information about objects displayed on the chart.

- To display detailed object information:
 1. Using the trackpad, place the cursor over the desired object.
 2. In chart mode, press **ENTER**; the primary function bar is displayed:

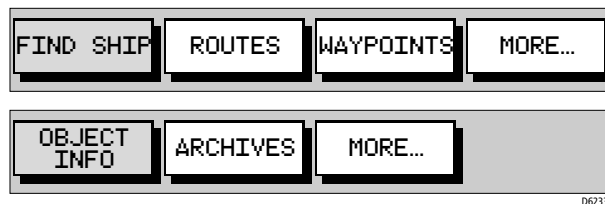

3. Using trackpad left/right, select OBJECT INFO.
A list of cartography objects under the cursor is displayed.
4. Use the trackpad up/down to select the desired object and press **ENTER** for detailed information.
5. Use the trackpad up/down and left/right to scroll through the detailed information.
6. Press **CLEAR** three times to return to normal operation.

Note: For best results, use the OBJECT INFO function in a close range chart view.

5.9 Using Archives

The ARCHIVE function is used to save routes, tracks and waypoints to the Gold Chart card. This is particularly useful if you use a lot of routes, tracks or waypoints and do not wish to repeatedly re-enter these. Once you have archived your data to the card, the copy on the chartplotter can be deleted, thus freeing up memory.

Note: A typical 32Mb Gold Chart card will hold up to 500 waypoints or 20 routes, each with up to 50 waypoints. If the Gold Chart card also contains chart files then these values will be lower.

Archiving a Route

► To archive a route:

1. In chart mode, press **ENTER**; the primary function bar is displayed:

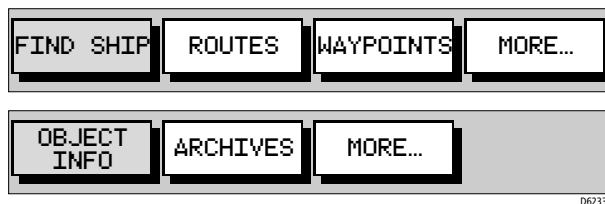

2. Using trackpad left/right, select ARCHIVES.



3. Select ARCHIVE ROUTE. A list of routes currently loaded in the chartplotter is displayed. Use trackpad up/down to select the route you wish to archive and press **ENTER**. To leave without archiving, press **CLEAR**.

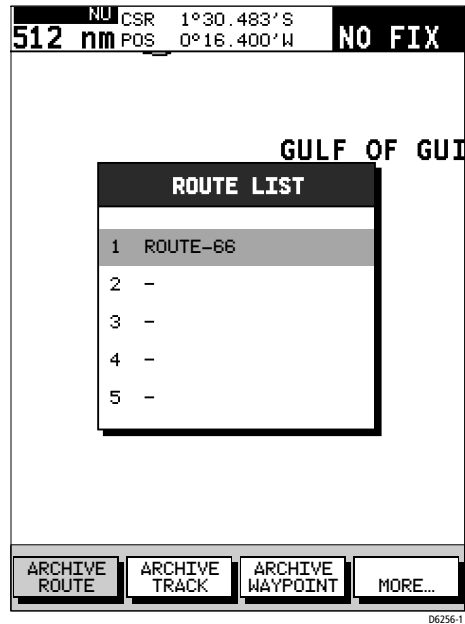

Figure 5-11: Archiving a Route

4. You can now (if desired) change the name of the archived file. Use trackpad left/right and up/down to change. Press **ENTER** when complete.
5. The route is now archived. Press **CLEAR** twice to return to normal operation.

Note: Once archived, the route can be erased from the chartplotters memory to free up space. See *Erasing or (re)Naming a Route* on page 61.

Loading or Deleting an Archived Route

Using the ROUTE ARCH. LIST function, a previously archived route can be loaded back into the chartplotters memory, renamed or deleted.

► To load, delete or rename a route from the archive:

1. In chart mode, press **ENTER**; the primary function bar is displayed:

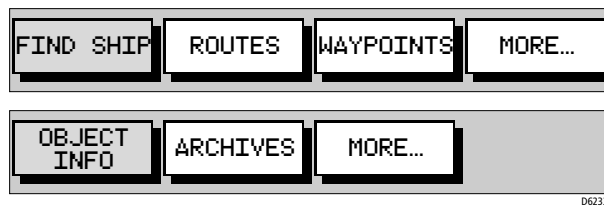

2. Using trackpad left/right, select ARCHIVES.



3. Using trackpad left/right, select MORE... and then ROUTE ARCH. LIST.

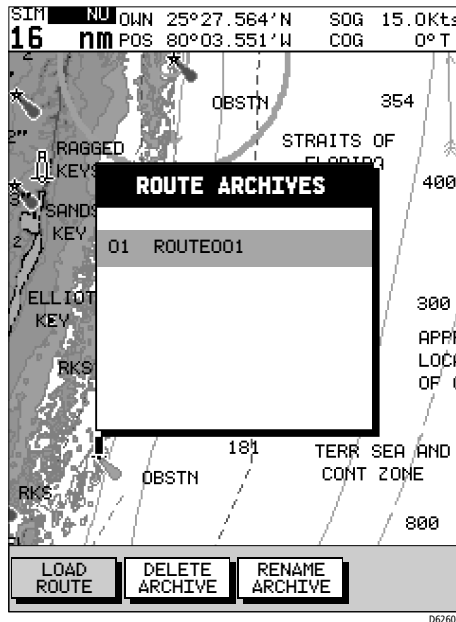

Figure 5-12: Route Archive List

4. A list of archived routes is displayed.
 - To load a route from the archive:
Use trackpad up/down to select the route you wish to load and press **ENTER**.
 - To delete a route from the archive:
Use trackpad up/down to select the route you wish to delete, then use the trackpad left/right to select DELETE ARCHIVE and press **ENTER**.
 - To rename a route in the archive:
Use trackpad up/down to select the route you wish to rename, then use the trackpad left/right to select RENAME ARCHIVE and press **ENTER**.
The first character of the selected route name will be highlighted. Use the trackpad left/right to select the character and up/down to change. When your changes are complete, press **ENTER** to save or **CLEAR** to discard any changes.

Archiving a Track

- To archive a track:

1. In chart mode, press **ENTER**; the primary function bar is displayed:



2. Using trackpad left/right, select ARCHIVES.



3. Select ARCHIVE TRACK. You can now (if desired) change the name of the track to be archived. Use trackpad left/right and up/down to change. Press **ENTER** when complete. To leave without archiving, press **CLEAR**.

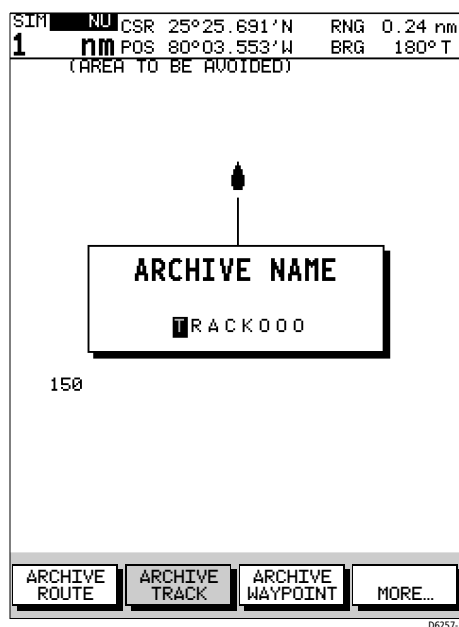

Figure 5-13: Archiving a Track

- The track is now archived. Press **CLEAR** twice to return to normal operation.

Note: Once archived, the track can be cleared from the chartplotters memory to free up space. (See *Clearing the Current Track on page 84*)

Loading or Deleting an Archived Track

Using the TRACK ARCH. LIST function, a previously archived track can be loaded back into the chartplotters memory, renamed or deleted.

- To load, delete or rename a track from the archive:
 - In chart mode, press **ENTER**; the primary function bar is displayed:

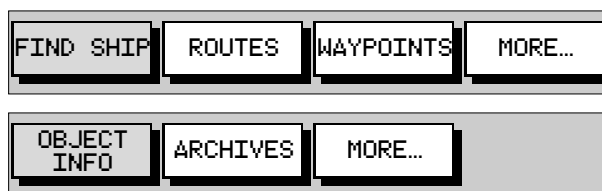

2. Using trackpad left/right, select ARCHIVES.



3. Using trackpad left/right, select MORE... and then TRACK ARCH. LIST.

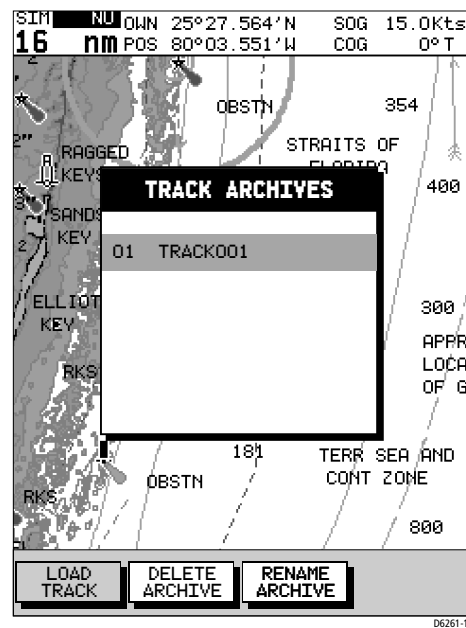

Figure 5-14: Track Archive List

4. A list of archived tracks is displayed.
 - To load a track from the archive:
Use trackpad up/down to select the track you wish to load and press **ENTER**.
 - To delete a track from the archive:
Use trackpad up/down to select the track you wish to delete, then use the trackpad left/right to select **DELETE ARCHIVE** and press **ENTER**.

- To rename a track in the archive:
Use trackpad up/down to select the track you wish to rename, then use the trackpad left/right to select **RENAME ARCHIVE** and press **ENTER**.
The first character of the selected track name will be highlighted. Use the trackpad left/right to select the character and up/down to change. When your changes are complete, press **ENTER** to save or **CLEAR** to discard any changes.

Archiving a Waypoint Set

- To archive the waypoints currently loaded on the system:
 1. In chart mode, press **ENTER**; the primary function bar is displayed:

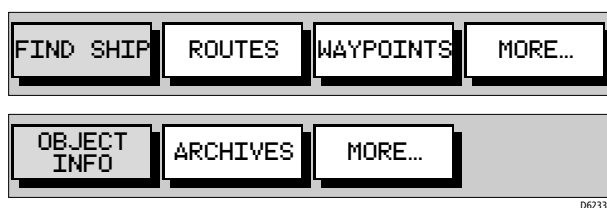

2. Using trackpad left/right, select **ARCHIVES**.



3. Select **ARCHIVE WAYPOINT**. You can now (if desired) change the name of the waypoint set to be archived. Use trackpad left/right and up/down to change. Press **ENTER** when complete. To leave without archiving, press **CLEAR**.



Figure 5-15: Archiving a Waypoint

4. The waypoint set is now archived. Press **CLEAR** twice to return to normal operation.

Note: Once archived, waypoints can be erased from the chartplotters memory to free up space. (See Erasing Waypoints on page 54.)

Loading or Deleting an Archived Waypoint Set

Using the WAYPOINT ARCH. LIST function, a previously archived waypoint set can be loaded back into the chartplotter, renamed or deleted.

- To load, delete or rename a waypoint set from the archive:
 1. In chart mode, press **ENTER**; the primary function bar is displayed:

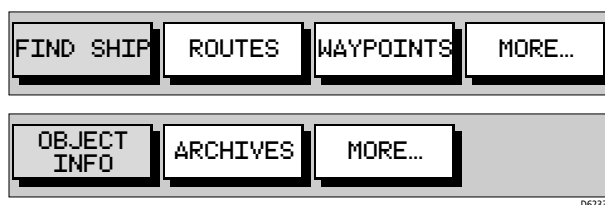

- Using trackpad left/right, select ARCHIVES.



- Using trackpad left/right, select MORE... and then WAYPOINT ARCH. LIST.

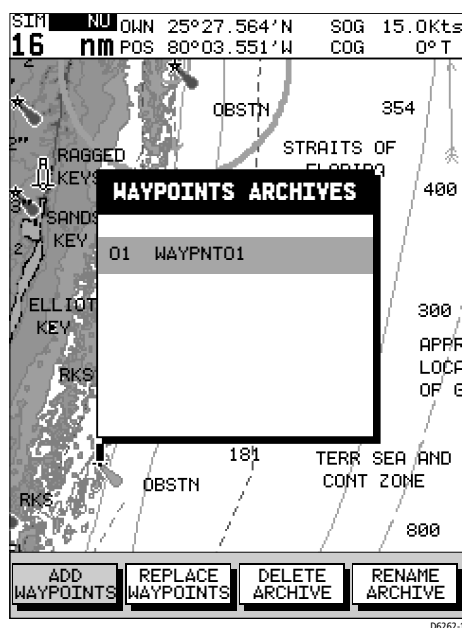

Figure 5-16: Waypoint Archive List

- A list of archived waypoint sets is displayed.

Note: When loading waypoint sets onto the chartplotter, you can either add to the waypoints currently loaded on the chartplotter or replace the waypoints currently loaded.

- To load a waypoint set from the archive:
 - Use trackpad up/down to select the waypoint set you wish to load, use the trackpad left/right to select either ADD WAYPOINTS or REPLACE WAYPOINTS and press **ENTER**.

- To delete a waypoint set from the archive:
Use trackpad up/down to select the waypoint set you wish to delete, then use the trackpad left/right to select DELETE ARCHIVE and press **ENTER**.
- To rename a waypoint set in the archive:
Use trackpad up/down to select the waypoint set you wish to rename, then use the trackpad left/right to select RENAME ARCHIVE and press **ENTER**.
The first character of the selected waypoint set name will be highlighted. Use the trackpad left/right to select the character and up/down to change. When your changes are complete, press **ENTER** to save or **CLEAR** to discard any changes.

5.10 Displaying Chart Information

Gold Chart cards include a number of displayed objects for which data is available, such as lights, buoys, ports or tidal data. Placing the cursor over an object displays its associated data in a pop-up box. Typical examples for Port Services and Tide Information are given below.

Port Services

Port information is indicated by the  symbol.

At detailed chart scales, placing the cursor over a port symbol enables detailed information to be displayed. The port facilities are listed in the object information pop-up and, where available, details for each facility can be displayed.

In some areas the chart shows symbols for individual facilities. These facilities and symbols are dependent upon the particular area Gold Chart card used.

- To obtain port services information
 1. Place the cursor over the port symbol for which information is desired. The PORT SERVICES function and help text are displayed:

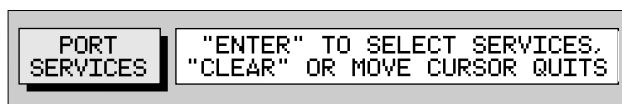

D4707_1

2. To view the port services available, press **ENTER**. The available services are listed on-screen in an object information pop-up:

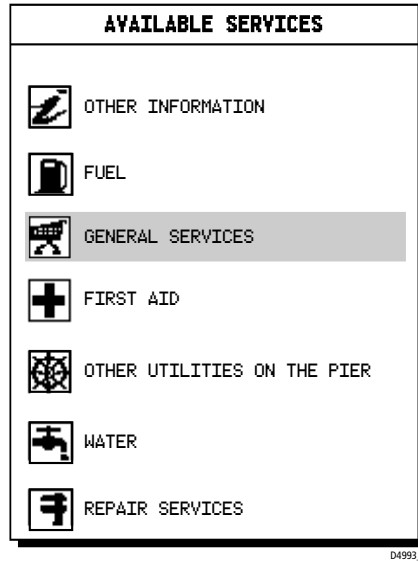

Figure 5-17: Available Port Services

3. Use the trackpad to select the desired service and press **ENTER** to display further details:

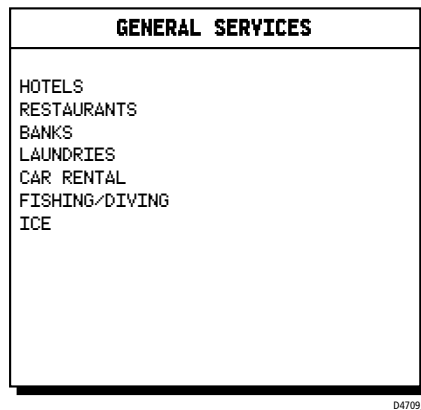

Figure 5-18: Port Service Details

4. To see more options (if available), select the.....**More**..... option and press **ENTER**.
5. Press **CLEAR** to remove the pop-up from the screen.

Tide Information

At detailed chart scales, placing the cursor over a Tide Height or Current symbol for more than 0.5 seconds enables detailed tide information to be displayed in an object information pop-up box. Soft keys enable Sun/Moon Data and Previous/Next Day information to be displayed.

Tidal Height

► To obtain Tide Height Data:

1. Place the cursor over a Tide Height symbol .
The Tidal Heights soft key and help text appear.

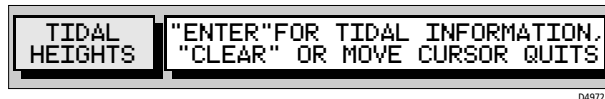

2. Press **ENTER** to show the Tidal Heights information (*Figure 5-19*) or **CLEAR** to cancel the operation. If no Fix is available (to provide date information), a warning box appears.

The “Port Name” is that supplied by the Gold Chart cartridge. The Tidal Height graph is automatically scaled. The cursor, represented by a dashed line, can be moved along the horizontal axis by means of the Trackpad. A CURSOR data box below the graph shows corresponding TIME and HEIGHT.

Times and heights of HIGH WATER and LOW WATER are shown.

DATE and TIME for TODAY (default) are shown with PREVIOUS/NEXT DAY information available via the MORE OPTIONS soft key; repeated presses of these two soft keys moves the date back/forward one day at a time.

3. To return to chart display, press **CLEAR**.

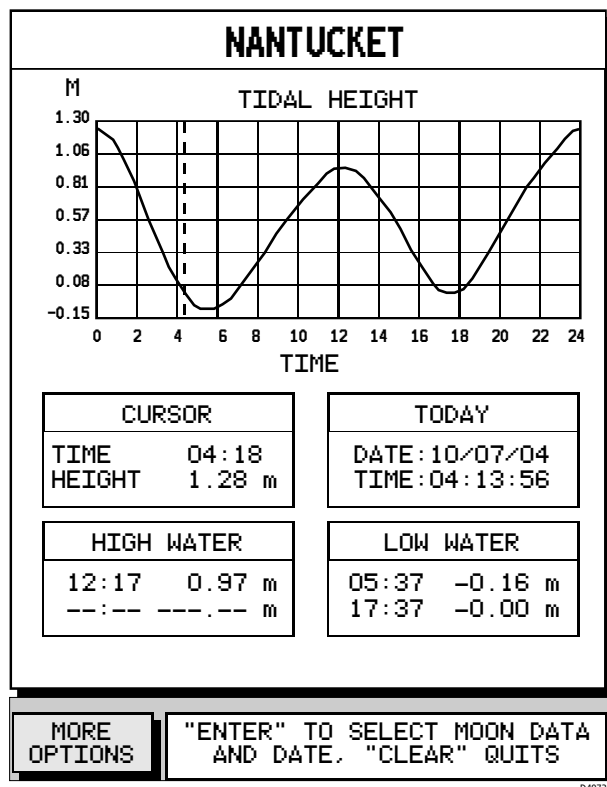
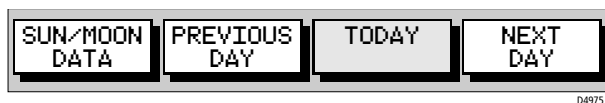

Figure 5-19: Tidal Height Display

- To display the Tide Height at a particular Date/Time:
1. Press **ENTER** to select MORE OPTIONS; the SUN/MOON DATA soft keys.



2. Using trackpad left/right, select PREVIOUS DAY or NEXT DAY soft key; press **ENTER** the appropriate number of time.
3. Press **CLEAR** to return to the MORE OPTIONS function bar. Using trackpad left/right, move the cursor to the desired time of day. The Cursor box shows the Tide Height for that particular Date/Time.
4. Select TODAY to return to current Date/Time.

► To display Sun/Moon data:

1. Select SUN/MOON DATA.

The SUN rise/set and MOON rise/set times are displayed.

The MOON PHASE box indicates the number of days referred to full moon, together with a pictorial representation.

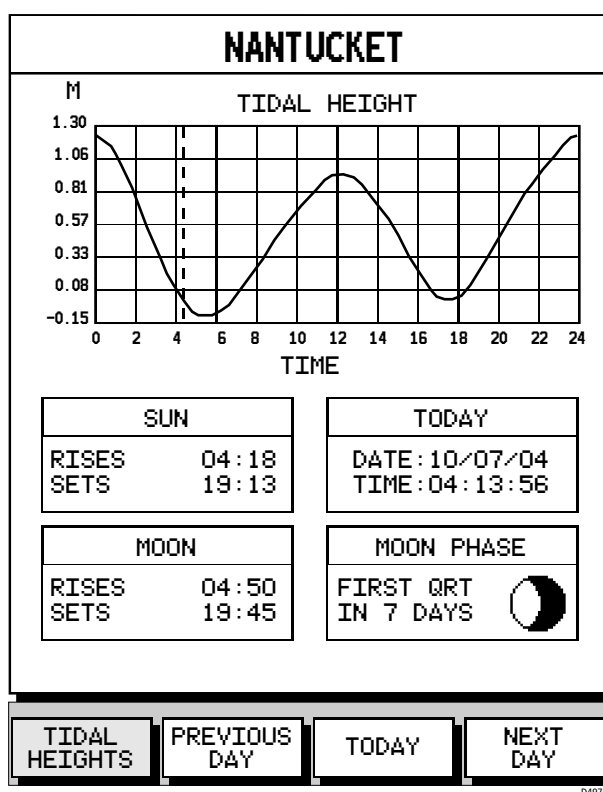



Figure 5-20: Tidal Heights & Sun/Moon Data Display

2. Select TIDAL HEIGHTS or press **CLEAR** to return to the Tidal Heights data.

Tidal Current

► To obtain Tidal Current Data:

1. Place the cursor over a Tide Current symbol .
The Tidal Current soft key and help text appear.

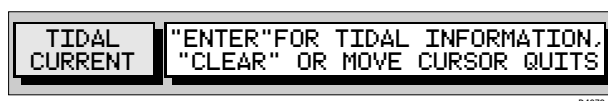

D4978-1

2. Press **ENTER** to show the Tidal Current information and soft keys or **CLEAR** to cancel the operation.

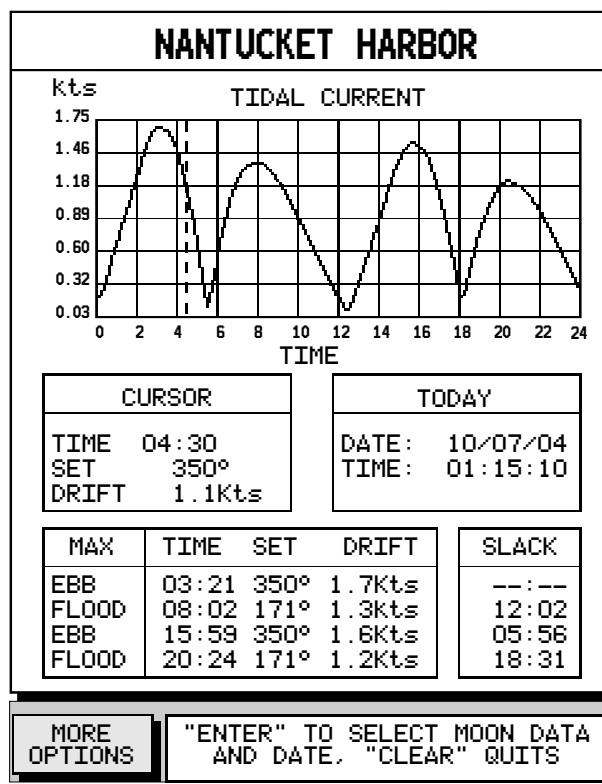

D4979-4

Figure 5-21: Tidal Current Display

The “Port Name” is that supplied by the Gold Chart cartridge. The Tidal Current graph is automatically scaled. The cursor, represented by a dashed line, can be moved along the horizontal axis by means of the Trackpad. A CURSOR data box below the graph shows corresponding TIME, SET and DRIFT.

DATE and TIME for TODAY (default) are shown with PREVIOUS/NEXT DAY information available via the MORE OPTIONS soft key; repeated presses of these two soft keys moves the date back/forward one day at a time.

Times of MAXimum EBB and FLOOD Tides, together with SET and DRIFT figures are shown. A separate box shows corresponding SLACK figures. This data corresponds to the selected Date/Time.

3. To return to chart display, press **CLEAR**.

➤ To display the Tidal Current data for a particular Date:

1. Press **ENTER** to select MORE OPTIONS; the SUN/MOON DATA soft keys are shown.



2. Using trackpad left/right, select PREVIOUS DAY or NEXT DAY soft key; press **ENTER** the appropriate number of times to select the desired Date.
3. Select TODAY to return to current Date/Time.

➤ To display Sun/Moon data:

1. Select SUN/MOON DATA; the SUN rise/set and MOON rise/set times are shown in individual boxes.
The MOON PHASE box indicates the number of days referred to full moon, together with a pictorial representation.
2. Select TIDAL CURRENT or press **CLEAR** to return to the Tidal Current data.

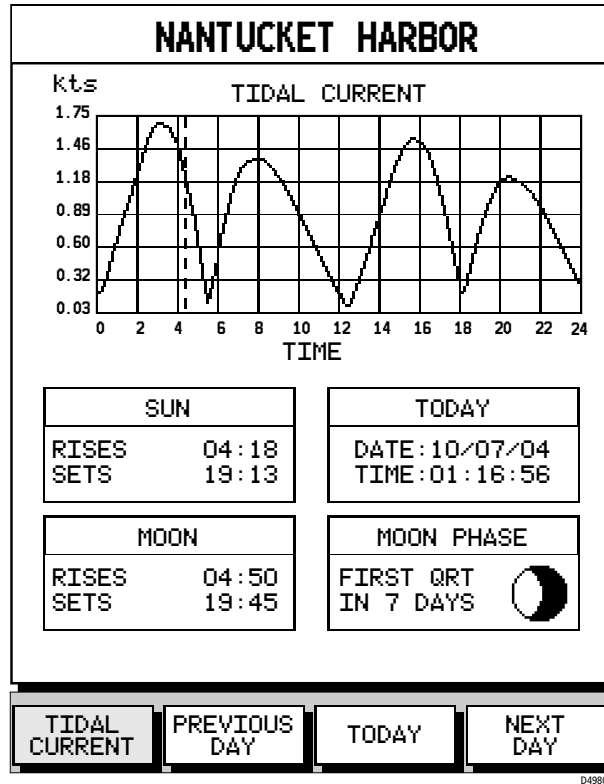

Figure 5-22: Tidal Current & Sun/Moon Data Display

5.11 Man Overboard (MOB)

If a person or object is lost overboard, and you need to return to the location, use the Man Overboard (MOB) function.

Note: *To obtain MOB position, a valid GPS fix must be available.*

- To initiate the MOB procedure from the Chart display, **press and hold** the **GOTO** key for two seconds. The system performs the following tasks automatically:
 - Stops any GoTo or Follow operation
 - Selects a $1/8$ nm scale (even if cartography is not available)
 - Marks the current position as a temporary waypoint with an MOB symbol which replaces any current active waypoint and route
 - Displays the MOB data box, showing the bearing and range to the MOB position, the elapsed time since the MOB was initiated and COG data

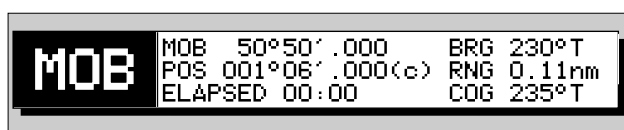

- Sends an MOB message, including bearing and range, to other units in the system, via NMEA

Notes: (1) A “(c)” character following the position data (POS) indicates that the vessel’s position has been User Calibrated. See Chapter 4, Setting Up.

Notes: (2) The **RANGE** key operates normally to change chart scale.

- To cancel MOB, press and hold the **GOTO** key for 2 seconds. The MOB symbol and data box are removed and the unit returns to normal Chart mode.

5.12 Alarms

The chartplotter reports the following alarms

Alarm	Indicates
Arrival	The vessel has arrived at the active waypoint: it has either reached the arrival circle (the radius of which is specified) or, has reached its closest point of approach (defined by a line passing through the waypoint and perpendicular to the track).
XTE	The vessel has exceeded the specified distance (maximum cross track error) from the active route leg.
Anchor	The vessel has drifted from its anchor position (set when the alarm was turned on) by more than the specified distance.
No Fix	GPS fix or Differential data has been lost for more than 30 s.

The alarms are switched on or off, and the limits set, using the Chart Set Up function via the **PAGE** key menu. See *Chapter 4, Chart Set Up Parameters* on page 38.

When an alarm is triggered, the alarm buzzer sounds and a pop-up box describing the alarm is displayed.

- To silence the alarm and clear the message, press any key.

Chapter 6: Maintenance & Troubleshooting

This chapter provides information on routine maintenance and problem solving associated with your RC435/435i Chartplotter and/or its antenna.

6.1 Maintenance

CAUTION:

The chartplotter contains high voltage and specialized circuits only accessible to qualified service technicians - there are no user serviceable parts or adjustments and the operator should not attempt to service the equipment. The operator should not remove the rear cover.

Routine Checks

The Chartplotter is a sealed unit. Maintenance procedures are therefore limited to the following periodic checks:

- Wipe the display unit clean with a damp cloth
- Examine the cables for signs of damage, such as chafing, cuts or nicks
- Check that the cable connectors are firmly attached and that the connections to the vessel's DC power are clean and tight
- Ensure that the cartridge cover is always fitted correctly

Note: *Never use chemical or abrasive materials to clean the chartplotter. If the unit is dirty, wipe it with a clean, damp cloth.*

Servicing and Safety

Raymarine equipment should be serviced only by authorized Raymarine service technicians. They will ensure that service procedures and replacement parts used will not affect performance. There are no user serviceable parts in any Raymarine product.

Some products generate high voltages, so never handle the cables/connectors when power is being supplied to the equipment.

When powered up, all electrical equipment produces electromagnetic fields. These can cause adjacent pieces of electrical equipment to interact with one another, with a consequent adverse effect on operation.

To minimize these effects and to give you the best possible performance from your Raymarine equipment, guidelines are given in the installation instructions that enable you to ensure minimum interaction between different items of equipment, that is, to ensure optimum Electromagnetic Compatibility (EMC).

Always report any EMC-related problem to your nearest Raymarine dealer. We use such information to improve our quality standards.

In some installations, it may not be possible to prevent the equipment from being affected by external influences. In general this will not damage the equipment but it can lead to spurious resetting action, or momentarily may result in faulty operation.

6.2 Resetting the System

Two types of reset are available for the Chartplotter:

- **Power-On Reset:** When you turn the display unit off, then on again, the screen reverts to the chart display with all windows cleared.
- **Factory Reset:** This resets all values back to their original factory settings. The factory default settings are listed in *Chapter 4*.

Note: *Take care—factory reset clears all Waypoint and Route databases.*

To perform a factory reset:

1. Power off the unit.
2. Press and hold **CLEAR** while powering up until <Erase backup procedure> is displayed.
3. Either press **CLEAR** to abort Factory Reset and resume normal Power-Up or press **ENTER** to continue Factory Reset.
4. Press **ENTER** again; the unit restarts as for a first time Power Up with all values reset to their original factory settings.

6.3 Problem Solving

Prior to packing and shipping, all Raymarine products are subjected to comprehensive test and quality assurance programmes. However, if this unit should develop a fault, please refer to the following table to identify the most likely cause and the corrective action required to restore normal operation.

If you still have a problem after referring to the table, contact your local dealer, national distributor or Raymarine Technical Services for further advice.

Always quote the product serial number.

Troubleshooting

As a guide to problem solving, common problems and their possible causes are detailed below.

Problem	Correction
Unit does not function	<ol style="list-style-type: none"> 1. Make sure that the power supply cable is undamaged and that all connections are tight and free from corrosion. 2. Check polarity of the DC power cables for proper connection. Reconnect cables if necessary. 3. Check in-line fuse. Replace if necessary. 4. Check vessel's power (battery) for correct voltage readings (10.0–18.0 VDC).
Poor display definition	Adjust contrast setting and/or backlight level.
No position information	Check the GPS Antenna connection Check the GPS Antenna (RC435 only)
No fix	Check that GPS Antenna not obstructed and able to get clear direct line of sight view of satellites in the sky.
No NMEA data received	Check the POWER/NMEA connector and the NMEA equipment. Note that NMEA OUT from one product connects to NMEA IN on another product and vice versa.
Loss of stored data, waypoints	Return to dealer for internal battery check. Note that the Waypoint database is cleared when a Factory Reset is performed.

Problem	Correction
No detailed chart data	Check that Gold Chart card is pushed fully home Check that the Gold Chart card has appropriate cartography.
Other problems	Visit our website at www.raymarine.com .

6.4 How to Contact Raymarine

On the Internet

Visit the Raymarine World Wide Web site for the latest information on Raymarine electronic equipment and systems at:

www.raymarine.com

Customer Support

Navigate to the **Customer Support** page for links to:

- Finding Factory Service locations and Authorized Dealers near you
- Registering your Raymarine products
- Accessing handbooks in Adobe Acrobat format
- Downloading RayTech software updates
- Accessing the Raymarine solution database

Clicking the **Find Answers** link routes you to our solution database. Search questions and answers by product, category, keywords, or phrases. If the answer you are seeking is not available, click the **Ask Raymarine** tab to submit your own question to our technical support staff, who will reply to you by e-mail.

In the US

Accessories and Parts

Many Raymarine accessory items and parts can be obtained directly from your authorized Raymarine dealer.

However, if you are in need of an item not available from the retailer, please contact Raymarine Technical Services at:

1-800-539-5539 ext. 2333, *or*
1-603-881-5200 ext. 2333.

Technical Service is available Monday through Friday 4:00 AM to 6:00 PM Eastern Time.

Please have the Raymarine item or part number ready when calling if placing an order. If you are not sure which item is appropriate for your unit, you should first contact the Technical Support Department to verify your requirements.

Technical Support

For technical support, call:

1-800-539-5539 ext. 2444, *or*
1-603-881-5200 ext. 2444.

Our Technical Support Specialists are available to answer questions about installing, operating and trouble-shooting all Raymarine products.

Questions can be sent directly to our Technical Support Department via the Internet. Point your browser to **www.raymarine.com** and click on the **Customer Support** link. From there, select **Find Answers** and click the **Ask Raymarine** tab.

Product Repair and Service

In the unlikely event your Raymarine unit should develop a problem, please contact your authorized Raymarine dealer for assistance. The dealer is best equipped to handle your service requirements and can offer timesaving help in getting the equipment back into normal operation.

In the event that repairs can not be obtained conveniently, product service may also be obtained by returning the unit to:

Raymarine, Inc.
Product Repair Center
22 Cotton Road, Unit D
Nashua, NH 03063-4219

The Product Repair Center is open Monday through Friday 8:15 a.m. to 5:00 p.m. Eastern Time. All products returned to the Repair Center are registered upon receipt. Should you wish to inquire about the repair status of your unit, contact the Product Repair Center at:

1-800-539-5539 ext. 2118, *or*
1-603-881-5200 ext. 2118.

Please have the product reference number, or unit serial number, ready when you call. We will do everything possible to make the repair and return your unit as quickly as possible.

In Europe

In Europe, Raymarine support, service and accessories may be obtained from your authorized dealer, or contact:

Raymarine Ltd
Anchorage Park
Portsmouth, Hampshire
England PO3 5TD
Tel: +44 (0) 23 9269 3611
Fax: +44 (0) 23 9269 4642

Technical Support

The Technical Services Department handles inquiries concerning installation, operation, fault diagnosis and repair. For technical helpdesk contact:

Tel: +44 (0) 23 9271 4713
Fax: +44 (0) 23 9266 1228

Accessories and Parts

Raymarine accessory items and parts are available through your authorized Raymarine dealer. Please refer to the lists of component part numbers and optional accessories in the Installation chapter of this manual and have the Raymarine part number ready when speaking with your dealer.

If you are uncertain about what item to choose for your Raymarine unit, please contact our Customer Services Department prior to placing your order.

Worldwide Support

Please contact the authorized distributor in the country.

Appendix A: Specifications

CE	Conforms to 89/336/EEC(EMC), EN60945:1997	
Size (H x W x D)	6.93in (176mm) x 7.0in (178mm) x 2.52in (64mm), excluding mounting bracket	
Weight	1.87 lb. (0.85 kg.)	
Environmental	Waterproofing:	To US Coast Guard Standard CFR46; suitable for external mounting
	Temp Range - Operating:	-10°C to 50°C
	Temp Range -Storage:	-20°C to 70°C
	Humidity	up to 95% RH
Mounting	Mounting Bracket or Panel Mount	
Power Input	10.0VDC to 18.0VDC 12VDC nominal	
	Consumption - Typical	<10W @12VDC including GPS
Controls	6 defined keys and trackpad	
Display type	TFT LCD	
Display	320 x 240 pixels (1/4VGA) color portrait	
Interfaces	Power/NMEA	NMEA 0183 receive and transmit Waypoint upload/download (WPL & RTE)
	GPS	12 Channel GPS Antenna with Satellite Differential capability
Cartography	Navionics Gold Chart cartridge	
Software update	Via Cartography cartridge interface	
Memory	Capacity:	Waypoints: 500 max (20 routes of up to 50 waypoints) Track history: 1000 points
GPS Frequency	1575.42 MHz \pm 1 MHz (C/A code), L1	
GPS Sensitivity	-130dBm	
GPS Signal acquisition	Automatic	

GPS Time to first fix	Cold start: Warm start: Hot start:	Typically < 3 min (4 min max) Typically < 60 seconds Typically < 8 seconds
GPS Position accuracy	<15m RMS. <5m with SD-GPS	
Geodetic Datum	WGS-84 (Customer Selectable Position Correction)	
GPS Antenna Cable length (RC435 only):	10m (33ft)	

Note: *The system is limited to 500 unique waypoints yet 20 routes of 50 waypoints as stated above are permissible. This figure is achieved by using waypoints in more than one route.*

NMEA Data

Connector	Transmitted	Received
POWER/NMEA	GGA, GLL, RMC, VTG, GSA, GSV, PRAYA,6, XTE, BWR, RMB, APB, WPL, RTE	WPL, RTE

Appendix B: List of Abbreviations

BDI	Bearing Deviation Indicator
BTW	Bearing To Waypoint
CDI	Course Deviation Indicator
COG	Course Over Ground. The actual direction of your vessel's movement over the ground.
dGPS	Differential Global Positioning System
DTG	Distance To Go
EMC	Electro-Magnetic Compatibility
ETA	Estimated Time of Arrival
GPS	Global Positioning System
HDOP	Horizontal Dilution Of Precision. The multiplicative factor that modifies ranging error. It is caused solely by the geometry between your vessel and your set of satellites.
MOB	Man OverBoard
NMEA	National Marine Electronics Association (interconnection standard)
SD	Satellite Differential
SOG	Speed Over Ground. The rate of movement of the vessel over the ground.
TTG	Time To Go
UTC	Universal Time Constant - also known as GMT
WPT	Waypoint
XTE	Cross Track Error

Index

A

- Abbreviations 113
- Alarms 104
 - Anchor 42
 - Man Overboard 103
 - XTE 42
- Archives 86–95
 - Archiving
 - Routes 86
 - Tracks 89
 - Waypoint Set 92
 - Deleting
 - Routes 88
 - Tracks 90
 - Waypoint Set 93
 - Loading
 - Routes 88
 - Tracks 90
 - Waypoint Set 93
- Arrival Circle 41
- Autozoom 41

B

- BDI Display 74
- Bearing Mode 35

C

- CDI Display 73
- Chart Boundaries 43
- Chart Scale 27
- Chart Setup 38–44
- Chart Text 42
- Cigarette Lighter Adapter 16, 19
- COG Vector 41
- Connectors 16
 - Antenna 16
 - NMEA 17
 - Power 17
- Contrast Level 22
- Cursor 2
- Customer Service 108

D

- Database Lists 4
- Date 36
- Dedicated Keys 3
- Depth Contours 43
- Depth Units 36
- Display Features 1
- Display Layout 1
 - Database Lists 4
 - Function Bar 3
 - Object Information 85
 - Pop-up Menus 4
 - Status Bar 3
- Display Mode 24, 72
 - BDI 74
 - CDI 73
 - Navigation Data 76
 - Time & Date 78
 - Waypoint Data 75
- Displaying a Chart 32
- Displaying Chart Information 95

E

- EGNOS 5
- EMC Guidelines 7

F

- Features 1
- Find Ship 26
- Function Bar 3

G

- Gold Chart Card 29
 - Current Information 100
 - Displaying a Chart 32
 - Displaying Information 95
 - Inserting 30
 - Loading a Chart 31
 - Object Information 85
 - Port Services 95
 - Removing 30
 - Tide Information 97
- GOTO 65
 - Cursor 70
 - Individual Target 69
 - Port 71

- STOP 72
- Waypoint 69
- GPS 4
- GPS Setup 44–46
- H**
- Help from Raymarine 108
- I**
- Installation 7
 - Cable Running 16
 - Chartplotter 12
 - Bracket Mounting 14
 - Panel Mounting 14
 - Connectors 16
 - EMC Guidelines 7
 - GPS 9
 - Pole Mounting 11
 - Surface Mounting 10
- K**
- Key Beep 35
- L**
- Language 36
- Light Sectors 43
- Lighting Level 22
- Loading a Chart 31
- M**
- Magnetic Variation 36
- Maintenance 105
 - Routine Checks 105
 - Servicing 105
 - System Reset 106
- Man Overboard 103
- Missing Items 8
- MSAS 5
- N**
- Navigation Data Display 76
- NMEA
 - Transferring Waypoints and Routes 80
- O**
- Object Information 85
- Operating Controls 1
 - Cursor 2
- Dedicated Keys 3
- Trackpad 2
- Orientation 40
- P**
- Plotter Mode 40
- Pop-up Menus 4
- Port Services 95
- Position Calibration 43
- Power cable 17
- Presentation 43
- R**
- Reset 106
- Restart XTE 68
- Routes 55–64
 - Alter 67
 - Archiving 86
 - Arrival at Target 67
 - Clearing 59
 - Create 56
 - Deleting a Waypoint 63
 - Deleting from Archive 88
 - Displaying Legs 60
 - Editing 63
 - Erasing 61
 - Follow a Route 66
 - Inserting a Waypoint 63
 - Join 67
 - Loading from Archive 88
 - Naming 61
 - Renaming 61
 - Restart XTE 68
 - Retrieving 59
 - Reverse a Route 66
 - Route Info 61
 - Saving current route 58
 - SmartRoute 84
 - Transferring via NMEA 80
 - Waypoint Advance 68
- S**
- Safety Contours 43
- Satellite Differential System 4–6
- Screen Amplifier 41
- SD-GPS 4

- Select Chart 42
 - Service 108
 - Servicing 105
 - Simulated COG 37
 - Simulated SOG 37
 - Simulator 23, 37
 - Speed Units 36
 - Spot Soundings 43
 - Status Bar 3
 - Stop Follow 72
 - Stop GOTO 72
 - Sun & Moon Data 98, 101
 - Switching Off 22
 - Switching On 19, 22
 - System Check 19
 - System Reset 106
 - System Setup 33–37
- T**
- Technical Support 108
 - Tidal Current 100
 - Tidal Height 97
 - Time 36
 - Time & Date Display 78
 - Trackpad 2
 - Tracks 82–84
 - Archiving 89
 - Clearing 84
 - Deleting from Archive 90
 - Interval settings 83
 - Loading from Archive 90
 - Setting up 82
 - SmartRoute 84
 - Troubleshooting 107
- V**
- Variation 36
- W**
- WAAS 5
 - Waypoint Advance 68
 - Waypoint Data Display 75
 - Waypoint Symbol 41
 - Waypoints 47–55
 - Adding to a Route 63
 - Archiving 92
 - Data 51
 - Deleting from a Route 63
 - Deleting from Archive 93
 - Displaying within a Route 60
 - Editing 52
 - Erasing 54
 - List 52
 - Loading from Archive 93
 - Moving 54
 - Placing 48
 - Selecting 50
 - Show 41
 - Symbol 41
 - Transferring via NMEA 80
 - WGS 84 position 44
- X**
- XTE Alarm 42

